

Bus Mirror Heater Timer Circuit

Circuit provides an adjustable timed power output to the mirror heating element when activated by the control switch.

Product Information

InPower Model: VCM-05.X Time Delay Solid State Relay, One-Shot

Description: The VCM-05.X is a solid state adjustable one-shot timer relay with a single +12 volt @ 15 amp output. The module has two inputs, one actuated by a transition to +12 volts (Input A) and one actuated by a transition to ground (Input B). The two inputs operate as a logical "Exclusive OR" so that either input can cause the timer to operate. If the module is not already in a time-out sequence, its output will be activated for the adjustable time period when +12 volts is applied to Input A while Input B is open, or when ground is applied to Input B while Input A is open. Once the timer has started, and the output activated, it will not be affected by the state of the input. The time period is adjustable with a single turn potentiometer. Time ranges available include: 0-10 seconds, 0-60 seconds, 0-3 minutes, 0-10 minutes, 0-60 Minutes, and fixed 120 seconds.

Available Models:	VCM-05.1	0 - 10 Seconds Time Range
	VCM-05.2	0 - 60 Seconds Time Range
	VCM-05.3	0 - 3 Minutes Time Range
	VCM-05.4	0 - 10 Minutes Time Range
	VCM-05.5	0 - 60 Minutes Time Range
	VCM-05.120S	Fixed 120 Seconds

Documentation: Product Data Sheet PDS-61

Operation

- Control Switch is turned on (This may be a momentary push button switch or a 2-position maintained switch).
- The mirror heating element is powered by the VCM-05.X output (terminal 30). The VCM-05.X keeps power on the heating element for a fixed period of time (VCM-5.X time setting) regardless of the Control Switch being in the open or closed position.

Application Wiring Diagram 1 (Control switch connected to +12 volts)

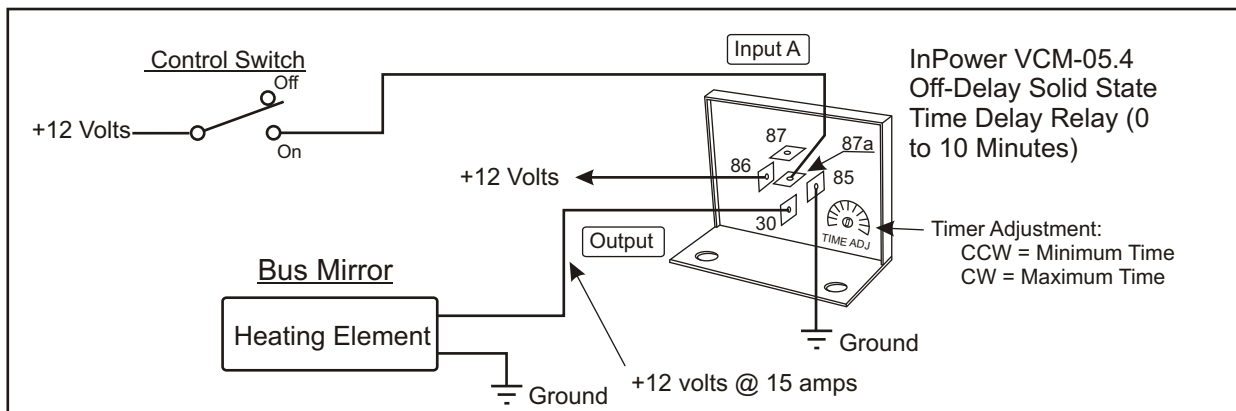

VCM Series

Application Bulletin

Application Wiring Diagram 2 (Control switch connected to ground)

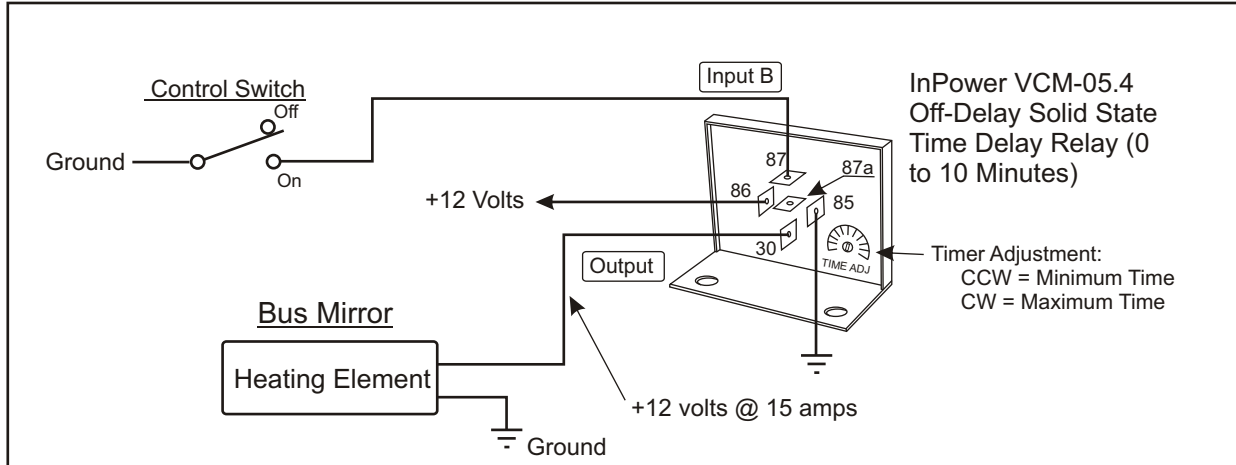

Application Wiring Diagram 3 (Control switches connected to ground and +12 volts)

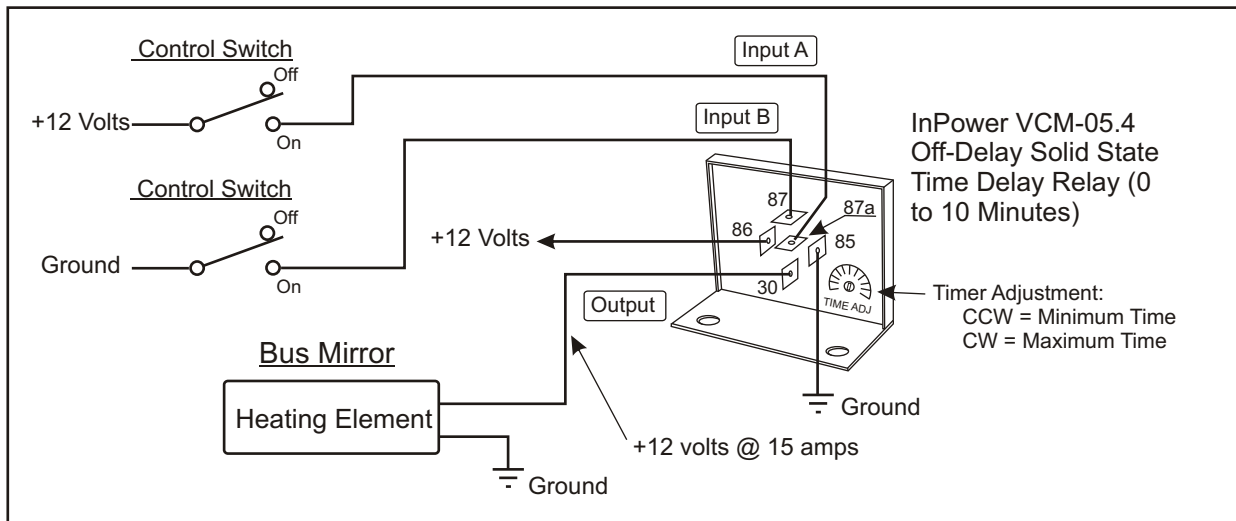

Timing Diagram

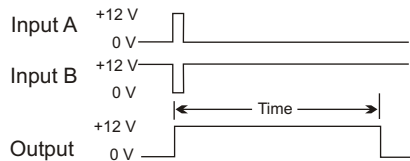

This timing diagram shows a short duration (e.g., Momentary) control switch operation. The switch activation starts the timed output pulse.

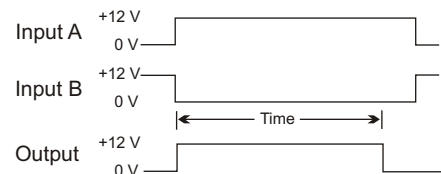

This timing diagram shows a long duration control switch operation. The leading edge of the switch activation activates the timed output pulse. The timed output will end regardless of the control switch being on or off.