

OWNERS MANUAL

Model SBF90 Eight Lamp School Bus Electronic Flasher

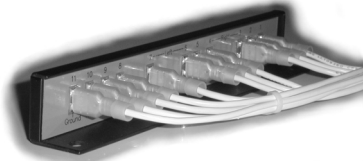

Introduction

The Model SBF90 flasher/controller is a completely electronic microprocessor based device dedicated to the school bus warning light application. It is comprised of a logic controller and a unique and highly efficient power switching circuit. The SBF90 operates the stop arm solenoid and eight 80 watt warning lamps. Inputs from the Start Switch and Passenger Door Switch activate the flasher/controller. Master Switch and Override Switch provisions are also included. Capabilities for both Sequential and Non-Sequential operation are provided.

The Model SBF90 flasher's circuitry is sealed to protect against severe environments and its internal construction is designed to withstand shock and vibration typically found in school bus applications. Wiring connections to the unit are via industry standard 0.25 inch Faston terminals.

Installation

The SBF90 should be located in a dry area such as the electrical compartment of the school bus. It should be accessible to the lamp wiring, 12 volt power, and ground. Mount the flasher on a clean, smooth metal surface to ensure the most effective heat transfer (the mounting plate removes heat from the flasher).

Before wiring the flasher/controller, disconnect the 12 volt power from the chassis by removing the battery connection.

Wire the flasher/controller to the required lights, ground, power and other devices as shown in the Wiring Diagrams and Technical Description sections. Ensure that the power wiring to the flasher/controller is fused. The fuse and wire size must be of sufficient size to protect the wiring and prevent from false tripping due to the lamp loads and high inrush currents. It is very important to provide a good ground to the unit. The wiring harness connecting to the flasher should be properly secured to prevent damage from vibration and stress on the connections.

Figure 1 Wiring Diagram - Eight Lamp Sequential Operation

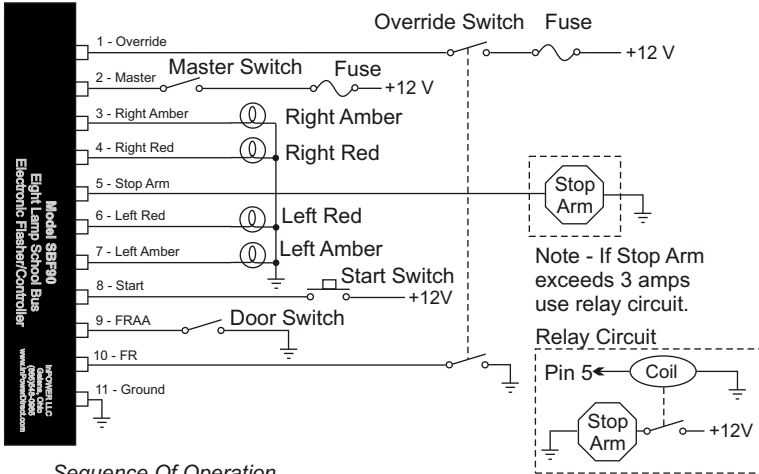

Sequence Of Operation

1. Start Switch is activated (momentary contact).
 2. Amber lights start flashing (alternately).
 3. Door Switch closes. Amber lights stop.
 4. Red lights start flashing and stop arm is actuated.
 5. Door Switch opens, red lights stop flashing and stop arm is retracted.
- Note - Anytime Override Switch is closed red lights start flashing immediately.

Figure 2 Wiring Diagram - Eight Lamp Non-Sequential Operation

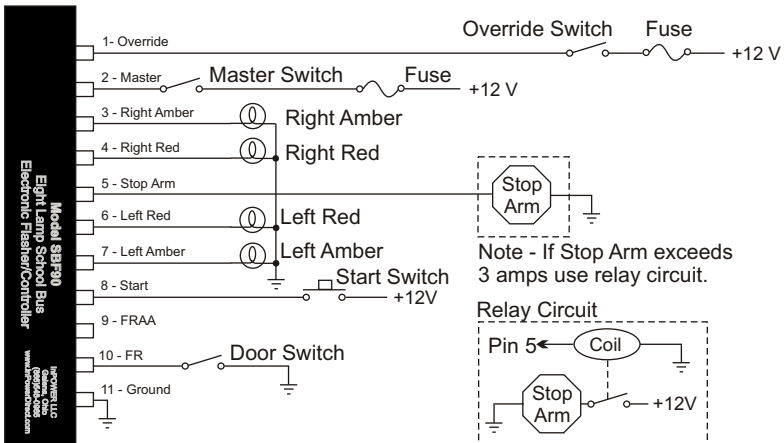

Sequence Of Operation

1. Start Switch is activated (momentary contact).
 2. Amber lights start flashing (alternately).
 3. Door Switch closes.
 4. Amber lights stop and red lights start flashing.
 5. Door Switch opens, red lights stop flashing.
- Note - Anytime the Door Switch or Override Switch is closed red lights start flashing immediately.

Figure 3 Wiring Diagram - Four Lamp Sequential Operation

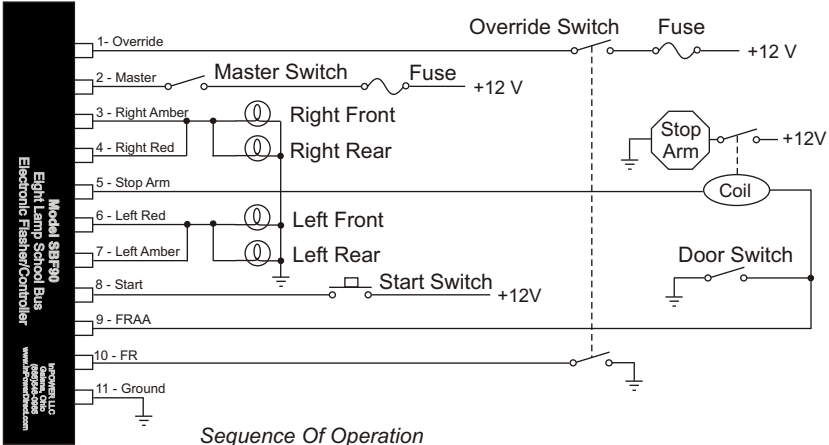

Sequence Of Operation

1. Start Switch is activated (momentary contact).
2. Red lights start flashing (alternately).
3. Door Switch closes.
4. Stop Arm is actuated and red lights continue to flash.
5. Door Switch opens, red lights stop flashing and Stop Arm is retracted.

Note - Anytime Override Switch is closed red lights start flashing immediately but Stop Arm only actuates when Door Switch is actuated.

Specifications

Operating Voltage:	8 to 16 Volts DC
Output Current Rating	
Lamps (Pins 3, 4, 6, & 7):	16 amps
Stop Arm (Pin 5):	3 amps
Operating Temperature:	-40 C to +85 C
Storage Temperature:	-50 C to +85 C
Terminals:	0.250 Inch Faston (11 total)

Mechanical Drawing

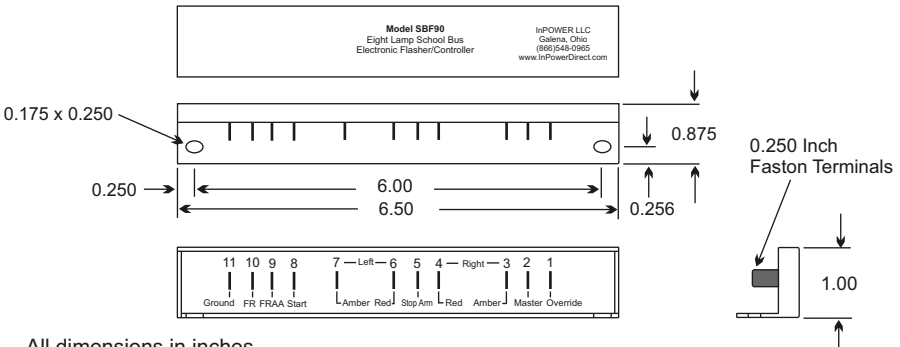

All dimensions in inches.

Technical Description

Override Switch (Pin 1 - Override)

An override switch may be used to function as a backup device as well as a means to immediately start the red lights flashing, bypassing the door switch and start button. The +12 volt power must be adequately fused. The override switch requires two contacts, one for Pin 1 and the second for Pin 10.

Master Switch (Pin 2 - Master)

This is the input for the 12 volt power, and must be adequately fused.

Right Amber Lights (Pin 3 - Right Amber)

This output provides the +12 volt power to flash the right front and right rear amber lights at a rate of 75 flashes per minute at a 50% duty cycle.

Right Red Lights (Pin 4 - Right Red)

This output provides the +12 volt power to flash the right front and right rear red lights at a rate of 75 flashes per minute at a 50% duty cycle.

Stop Arm (Pin 5 - Stop Arm)

This output supplies +12 volt power to actuate the stop arm device(s) when the red lights operate. If the load is more than 3 amps a relay circuit should be used (see Wiring Diagrams). Four lamp applications require different wiring (see Figure 3).

Left Red Lights (Pin 6 - Left Red)

This output provides the +12 volt power to flash the left front and left rear red lights at a rate of 75 flashes per minute at a 50% duty cycle.

Left Amber Lights (Pin 7 - Left Amber)

This output provides the +12 volt power to flash the left front and left rear amber lights at a rate of 75 flashes per minute at a 50% duty cycle.

Start Switch (Pin 8 - Start)

This input is from a momentary contact closure that supplies +12 volts to start the flash sequence.

Flash Red ONLY After Amber (Pin 9 - FRAA)

This grounded input from the door switch will cause the red lights to flash after the start switch is activated and the amber lights are flashing.

Flash Red When Door is Opened (Pin 10 - FR)

This grounded input from the door switch will cause the red lights to flash anytime the door is opened (non-sequential operation).

Ground (Pin 11 - Ground)

Logic and power ground for the flasher/controller unit. This must be a good quality ground connection.

Warranty

InPOWER LLC warrants its products to be free from defects in material and workmanship under normal use, care and maintenance for a period of two (2) years from the date of shipment. Please see www.inpowerdirect.com/warranty.htm for specifics or call 866-548-0965 for a copy of our warranty policy.

InPOWER LLC

3555 Africa Road
Galena, Ohio 43021

Tel 740-548-0965 Fax 740-548-2302
www.InPowerDirect.com

InPower wants to ensure total customer satisfaction. Please download a product evaluation form at www.InPowerDirect.com/customer_evaluation.htm or call us toll free at 866-548-0965 to be sent a form by mail.