

OWNERS MANUAL

Model SBF94

Eight Lamp School Bus Electronic Flasher/Controller



Introduction

The Model SBF94 flasher/controller is a completely electronic micro-processor based device dedicated to the school bus warning light application. Its +12 volt outputs operate the stop arm, stop arm lights, and eight 80 watt warning lamps. Inputs to unit include Master Switch, Override Switch, Start Switch and Service Door Switch. Its industry standard functionality can accommodate both sequential and non-sequential modes of operation.

The design provides safeguards for over current, over temperature, short circuit, and loss of ground. A highly efficient current switching circuit is employed that produces very little heat loss. Advanced electronic circuitry employs surface mount technology (SMT). Its metal case is made of rugged anodized aluminum.

The SBF94 utilizes the Tyco/Amp Multilock Series 070 connector system. The 12-pin header (containing male pins) is integral to the flasher case. The 12-pin connector plug (not supplied with the flasher) uses female pins.

Installation

The SBF94 should be located in a dry area such as the electrical compartment of the school bus. It should be accessible to the lamp wiring, 12 volt power and ground. Mount the flasher on a clean, smooth metal surface to ensure the most effective heat transfer (the mounting plate removes heat from the flasher).

Before wiring the flasher/controller, disconnect the 12 volt power from the chassis by removing the battery connection.

Wire the flasher/controller to the required lights, ground, power and other devices as shown in the Wiring Diagrams and Technical Description sections. Ensure that the power wiring to the flasher/controller is fused. The fuse and wire size must be of sufficient size to protect the wiring and prevent from false tripping due to the lamp loads and high inrush currents. It is very important to provide a good ground to the unit. The wiring harness connecting to the flasher should be properly secured to prevent damage from vibration and stress on the connections.

Figure 1 Wiring Diagram - Eight Lamp Sequential Operation

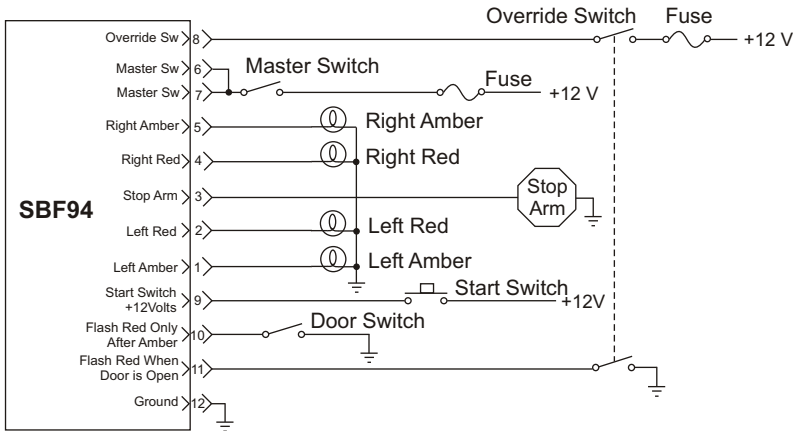

Sequence Of Operation

1. Start Switch is activated (momentary contact).
2. Amber lights start flashing (alternately).
3. Door Switch closes. Amber lights stop.
4. Red lights start flashing and stop arm is actuated.
5. Door Switch opens, red lights stop flashing and stop arm is retracted.

Note - Anytime Override Switch is closed red lights start flashing immediately.

Figure 2 Wiring Diagram - Eight Lamp Non-Sequential Operation

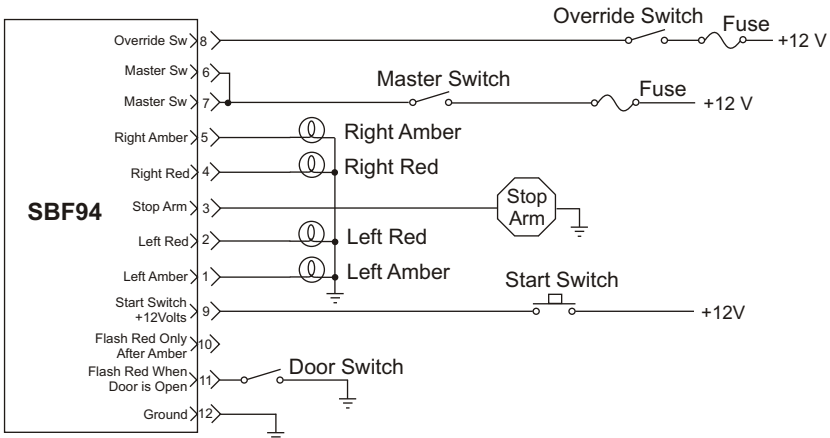

Sequence Of Operation

1. Start Switch is activated (momentary contact).
2. Amber lights start flashing (alternately).
3. Door Switch closes.
4. Amber lights stop and red lights start flashing.
5. Door Switch opens, red lights stop flashing.

Note - Anytime the Door Switch or Override Switch is closed red lights start flashing immediately.

Figure 3 Wiring Diagram - Four Lamp Sequential Operation

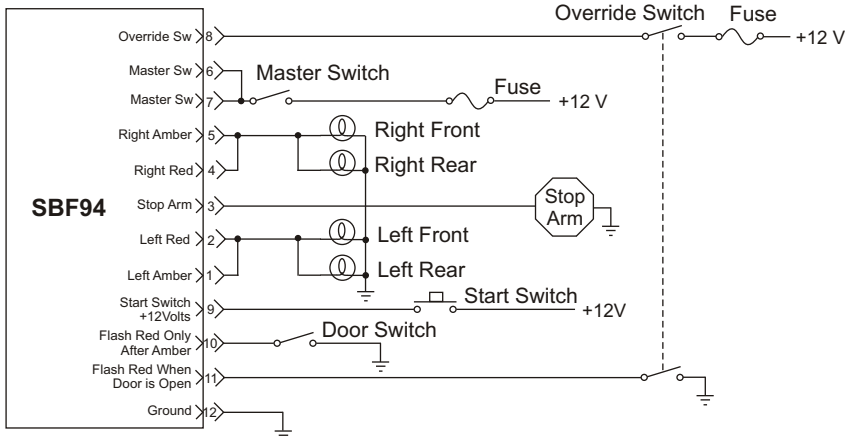

Sequence Of Operation

1. Start Switch is activated (momentary contact).
2. Red lights start flashing (alternately).
3. Door Switch closes.
4. Stop Arm is actuated and red lights continue to flash.
5. Door Switch opens, red lights stop flashing and Stop Arm is retracted.

Note - Anytime Override Switch is closed red lights start flashing immediately but Stop Arm only actuates when Door Switch is actuated.

Specifications

Operating Voltage:	8 to 16 Volts DC
Output Current Rating	
Lamps (Pins 7, 9, 10, & 12):	16 amps
Stop Arm (Pin 4):	3 amps
Operating Temperature:	-40 deg C to +85 deg C
Storage Temperature:	-50 deg C to +85 deg C

Mechanical Drawing

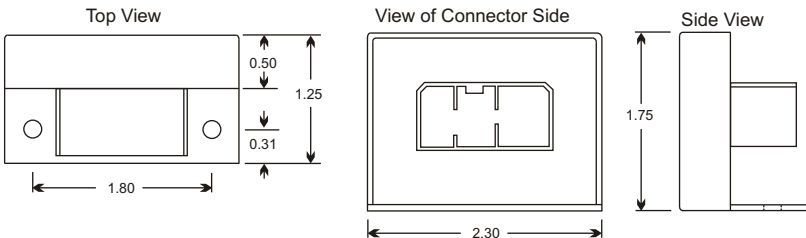

Connector Pin Layout

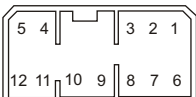

View looking into Amp Multilock 070 connector on flasher unit.

All dimensions in inches.

Connector Wiring

Start Switch (Pin 9)

This input is from a momentary contact closure that supplies +12 volts to start the flash sequence.

FRAA - Flash Red ONLY After Amber (Pin 10)

This grounded input from the door switch will cause the red lights to flash after the start switch is activated and the amber lights are flashing.

FR - Flash Red When Door is Opened (Pin 11)

This grounded input from the door switch will cause the red lights to flash anytime the door is opened (non-sequential operation).

Stop Arm (Pin 3)

This output supplies +12 volt power to actuate the stop arm device(s) when the red lights operate. If the load is more than 3 amps a relay circuit should be used (see Wiring Diagrams). Four lamp applications require different wiring (see Figure 3).

Ground (Pin 12)

Logic and power ground for the flasher/controller unit. This must be a good quality ground connection.

Left Amber Lights (Pin 1)

This output provides the +12 volt power to flash the left front and left rear Amber lights at a rate of 75 flashes per minute at a 50% duty cycle.

Override Switch (Pin 8)

An override switch may be used to function as a backup device as well as a means to immediately start the red lights flashing, bypassing the door switch and start button. The +12 volt power must be adequately fused. The override switch requires two contacts, one for Pin 8 and the second for Pin 11.

Right Amber Lights (Pin 5)

This output provides the +12 volt power to flash the right front and right rear amber lights at a rate of 75 flashes per minute at a 50% duty cycle.

Left Red Lights (Pin 2)

This output provides the +12 volt power to flash the left front and left rear red lights at a rate of 75 flashes per minute at a 50% duty cycle.

Master Switch (Pin 6, 7)

This is the input for the 12 volt power, and must be adequately fused.

Right Red Lights (Pin 4)

This output provides the +12 volt power to flash the right front and right rear red lights at a rate of 75 flashes per minute at a 50% duty cycle.

Warranty

InPOWER LLC warrants its products to be free from defects in material and workmanship under normal use, care and maintenance for a period of two (2) years from the date of shipment. Please see www.inpowerdirect.com/warranty.htm for specifics or call 866-548-0965 for a copy of our warranty policy.

InPOWER LLC

3555 Africa Road
Galena, Ohio 43021

Tel 740-548-0965 Fax 740-548-2302

www.InPowerDirect.com

InPower wants to ensure total customer satisfaction. Please download a product evaluation form at www.InPowerDirect.com/customer_evaluation.htm or call us toll free at 866-548-0965 to be sent a form by mail.