

Blank Page

InPOWER

the systems people

InPOWER LLC
 3555 Africa Road
 Galena, Ohio 43021 U.S.A
 (740)548-0965
 Www.InPowerLLC.com

Owners Manual

Document: OM-102

Date: Nov. 13, 2009

Version Code: A

Date: January 20, 2010

InPOWER

OWNERS MANUAL

ETM52-QVM and ETM52-QVM-2

Electronic Throttle Module

for Ford and GM Vehicles

**A. Introduction**

The InPower ETM52-QVM and ETM52-QVM-2 electronic throttle provides two modes of fast idle engine speed control for Ford and GM chassis with automatic transmissions. They contain Ford specified fast idle engine speeds and Automatic Mode battery voltage setpoints. Refer to InPowerLLC.com for a complete list of supported vehicles.

Two speed control modes are available: Automatic and Fixed Speed. The modes are activated from a customer supplied mode switch. The Fixed Speed Mode has priority over the Automatic Mode.

Fixed Speed Mode:

| | |
|-------------|--|
| Ford Diesel | 1200 rpm |
| Ford Gas | 1350 or 1500 rpm, selectable at installation |
| GM Diesel | 1350 or 1460 rpm, selectable at installation |
| GM Gas | 1350 or 1460 rpm, selectable at installation |

Automatic Mode:

This mode will cause the engine speed to increase to the fixed speed value of the Fixed Speed Mode when the battery voltage indicates a low charging condition. Normal idle speed is resumed when the battery voltage indicates a charged condition.

Note - On Ford gas engine chassis the ETM52-QVM is wired for a fast idle speed of 1350 RPM. This can be rewired at installation to operate at 1500 RPM. The ETM52-QVM-2 is wired for a fast idle speed of 1500 RPM. This can be rewired at installation to operate at 1350 RPM.

A wiring harness is supplied that connects to the electronic throttle control module via a 12-pin Amp Mate-N-Lok connector. This harness includes a cable with plug for connecting to the vehicle's OBD-II diagnostic connector, as well as a set of blunt-cut wires for the other interface connections. On Ford installations some of these blunt-cut wires connect to the Ford SEIC circuit's blunt-cut wires.

The ETM52 electronic throttle provides a transmission Park signal for GM vehicle applications. GM chassis installations utilize the cable to the OBD-II connector as well as blunt-cut wires for interface to the GM ECM PTO Enable Input, parking brake switch (C4500/C5500 diesel-only chassis), and a Park position for interlock functions.

Note that this manual contains separate sections for Ford installations and GM installations.

InPOWER

ETM52-QVM OM-102A

B. Operation

When the vehicle is parked and **Chassis Ready Conditions** are satisfied the engine speed may be controlled by one of the two available modes (Fixed Speed or Automatic).

Chassis Ready Conditions are:

1. Parking brake is set
2. Gear shift in "Park" (automatic transmission only)
3. Foot is off service brake
4. Foot is off the accelerator pedal
5. Vehicle is stationary (no speed)
6. Engine is started and idling below 900 rpm
7. Coolant temperature above 140° F (Ford Gas engine only)

Modes Of Operation:

1. Fixed Speed Mode:

When activated, the engine speed is increased to a fixed rpm value. This is established at installation as follows:

| | |
|--------------|----------------------|
| Ford Gas: | 1350 rpm or 1500 rpm |
| Ford Diesel: | 1200 rpm |
| GM Gas: | 1350 rpm or 1460 rpm |
| GM Diesel: | 1350 rpm or 1460 rpm |

2. Automatic Mode:

The engine speed is automatically increased to the module's Fixed Speed Mode rpm value when the battery voltage indicates a low charge condition and returns to normal idle when a charged condition is sensed. The battery voltage set points are:

1. If below 12.7 V instant turn on
2. If below 12.8 V turn on after one minute
3. If above 13.5 V turn off after one minute
4. If above 13.7 V instant turn off

Status Indicators

Eight LED indicators provides status and problem detection information. Refer to the following table for coding of these functions.

| LED | Status | Indication |
|--------|----------|--|
| RPM | On Solid | Fixed speed mode selected, engine at fast idle |
| RPM | Flashing | Fixed speed mode selected, engine <u>not</u> at fast idle* |
| CHRG | On Solid | Automatic mode selected, engine at fast idle |
| CHRG | Flashing | Automatic mode selected, engine <u>not</u> at fast idle (battery charged)* |
| PARK | On Solid | Transmission in PARK position |
| PARK | Flashing | Transmission <u>not</u> in PARK position |
| PK BRK | On Solid | Park Brake set |
| PK BRK | Flashing | Park Brake <u>not</u> set |
| SBRK | On Solid | Service Brake at rest (not activated) |
| SBRK | Flashing | Service Brake activated |
| VSPEED | On Solid | Vehicle stationary |
| VSPEED | Flashing | Vehicle moving |
| ACL | On Solid | Accelerator at rest (not depressed) |
| ACL | Flashing | Accelerator depressed |
| VIN | On Solid | Vehicle is supported |
| VIN | Flashing | Vehicle is not supported, has invalid VIN, or loss of communications. |

* The chassis engine control module (ECM) is not responding to the fast idle speed request. This could be caused by a chassis sensor interlock (See *Chassis Ready Conditions*), or some other PCM system problem.

E. Specifications

Electrical

Input Voltage (+12V Terminal): 8 to 16 volts
Input Current (+12V Terminal): 30 mA

Mechanical

Weight: 0.17 lbs
Connections: 12 Pin Amp Mate-N-Lok Connector
Case Material: Cylolac thermoplastic (UL 94V0)

F. Mechanical Drawing

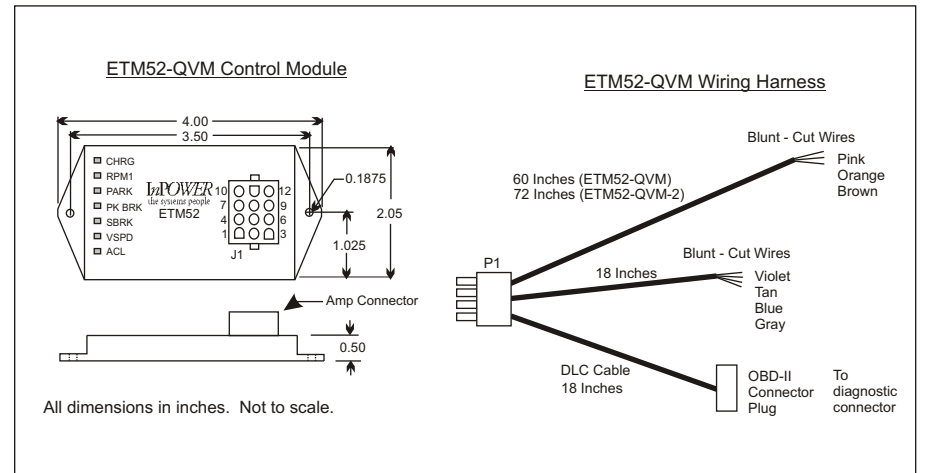

G. Customer Support

Technical Support

For product support, contact InPower at 740-548-0965 or 866-548-0965. Product bulletins and owner's manuals are available on our web site:

www.InPowerLLC.com.

Warranty

InPOWER LLC warrants its products to be free from defects in material and workmanship under normal use, care and maintenance for a period of two (2) years from the date of shipment. Please see www.inpowerdirect.com/warranty.htm for specifics or call 866-548-0965 for a copy of our warranty policy.

Customer Evaluation

InPower wants to ensure total customer satisfaction. Please download a product evaluation form at www.InPowerDirect.com/CustomerEvaluation.htm or call us toll free at 866-548-0965 to be sent a form by mail.

GM C4500 & C5500 CHASSIS WIRING DIAGRAM

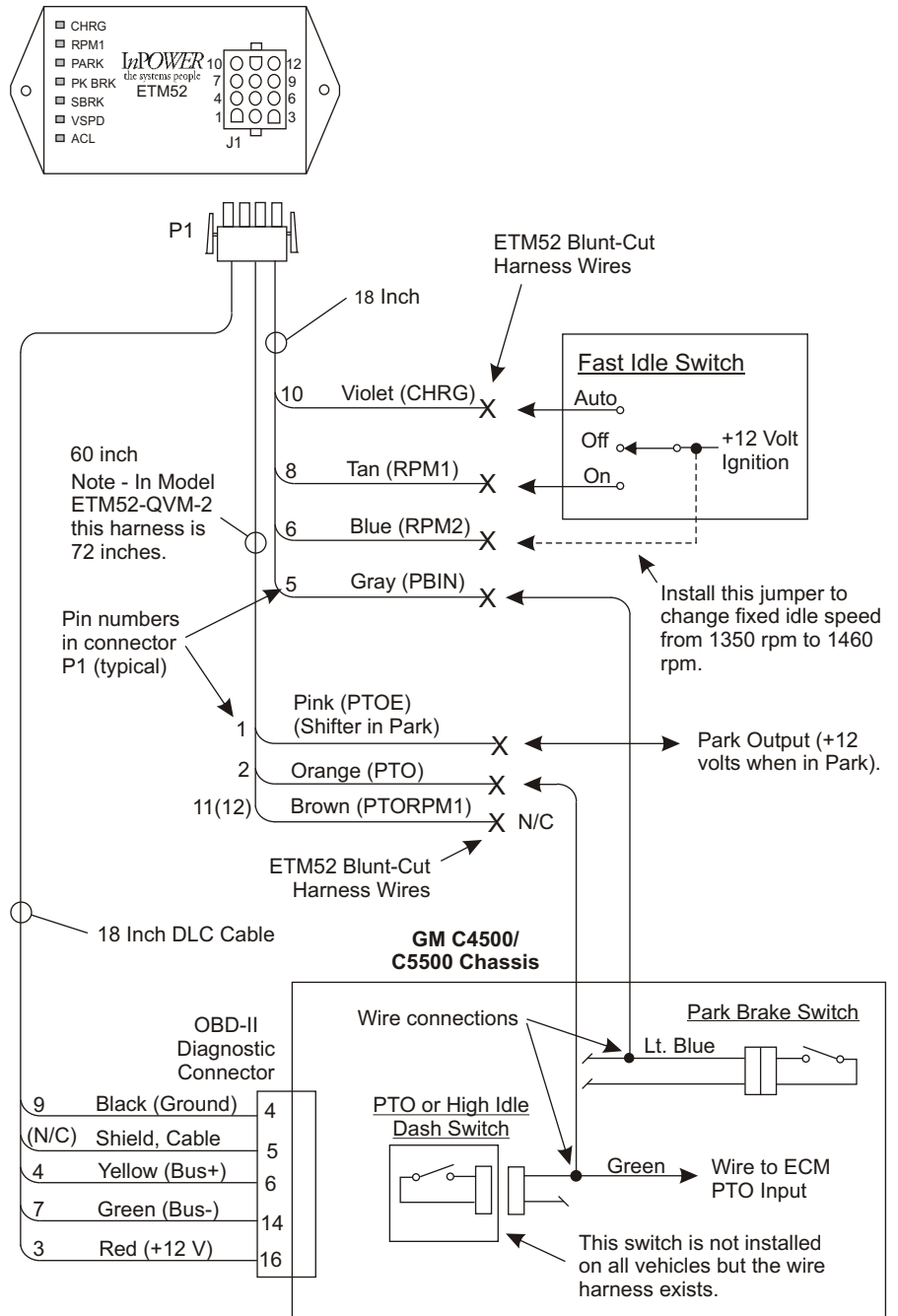

C. Installation - Ford Chassis

1. Getting Started

The recommended location for the electronic throttle system is under the dash due to the proximity of the wiring connections and cable length. **The unit should not be located in the engine compartment, or any location that is not protected. Do not lengthen the DLC Cable.**

2. Mount the Electronic Throttle Module

Disconnect the battery before making any connections. Mount the electronic throttle module under the dash using the two mounting holes. Ensure that you have sufficient distance to install the 18 inch long DLC cable.

3. Install the Wire Harness

Plug the 12-pin connector of the wiring harness into the electronic throttle module. Route the DLC cable to the OBDII Data Link Connector and plug it in. The OBDII connector is usually located on the lower part of the dash on the driver's side. Using a cable tie, secure the plug to the OBDII connector so that it will not vibrate out. We recommend that you route the DLC cable back across the bottom of the plug/connector, and loop the cable tie around the plug, socket and cable, thereby keeping the cable out of the way. Also ensure that the entire cable is routed and secured to keep it out of the way. In addition to the Data Link Cable, this wiring harness contains one group of 18 inch long blunt-cut wires and one group of 60 inch long blunt-cut wires. Connect these wires as described in the following paragraphs and as shown in the Ford wiring diagrams on pages 5 and 6.

4. Install the Fast Idle Switch

The electronic throttle system provides two modes of fast idle control: Automatic and Fixed Speed. The typical installation approach is to use a three-position driver's switch with an *Auto*, *Off* and *On* position. However, these two control modes can be configured differently. For example, you might desire just an Automatic function activated by an On-Off switch. Or a fixed speed fast idle function activated by another vehicle circuit.

Prior to installing the three-position Fast Idle Switch review the Ford gas and Ford diesel wiring diagrams on pages 5 and 6. Mount the switch in a convenient location. Locate the ETM52 wiring harness 18 inch long group of blunt-cut wires (Violet, Tan, Blue and Gray). Wire the Violet blunt-cut wire to the *Auto* position and the Tan wire to the *On* position of the Fast Idle Switch. The Blue and Gray wires will not be used. Fold them back and tape them to the loom. Wire the Fast Idle Switch common position to a +12 volt ignition circuit (+12 volts when the ignition switch is on).

5. Ford SEIC Wiring

The Ford SEIC circuit contains a set of color coded blunt-cut wires located in the engine compartment on the top, driver's side of the firewall. Refer to Ford SEIC documentation for more details. Some of these SEIC wires will be connected to the electronic throttle wiring harness 60 inch long blunt-cut wires (Pink, Orange and Brown). Note that different connections are required for diesel and gas engine vehicles.

C. Installation - Ford Chassis, Continued

Ford Diesel - Locate the SEIC Yellow/Green wire and connect it to the Orange wire in the electronic throttle harness. The Pink and Brown electronic throttle harness wires will not be used. Fold them back and tape them to the loom.

Ford Gas - Locate the SEIC Green, Yellow/Green and Blue/Green blunt-cut wires. Connect them to the ETM52 harness blunt-cut wires as follows:

SEIC Green (PTO RPM) to ETM52-QVMBrown
 SEIC Yellow/Green (PTO) to ETM52-QVM Orange
 SEIC Blue/Green (PTO ENGAGE) to ETM52-QVM Pink

Refer to Ford gas and diesel wiring diagrams on page 5 and 6.

Note on Ford Gas Installations - The ETM52-QVM Fixed Speed mode for Ford gas installations is 1350 rpm. This speed can be changed to 1500 rpm by the following procedure. Locate the Brown wire in the ETM52-QVM wiring harness. At the ETM52-QVM end of the harness the Brown wire is in pin position 11 (See Wiring diagram on page 5). Using an Amp Mate-N-Lok connector pin extractor #305183 remove the wire from pin 11 and install it in pin position 12.

The ETM52-QVM-2 Fixed Speed mode for Ford gas installations is 1500 rpm. This speed can be changed to 1350 rpm by the following procedure. Locate the Brown wire in the ETM52-QVM-2 wiring harness. At the ETM52-QVM-2 end of the harness the Brown wire is in pin position 12 (See Wiring diagram on page 5). Using an Amp Mate-N-Lok connector pin extractor #305183 remove the wire from pin 12 and install it in pin position 11.

This completes the Ford Installation portion of the manual.

GM GVAN WIRING DIAGRAM

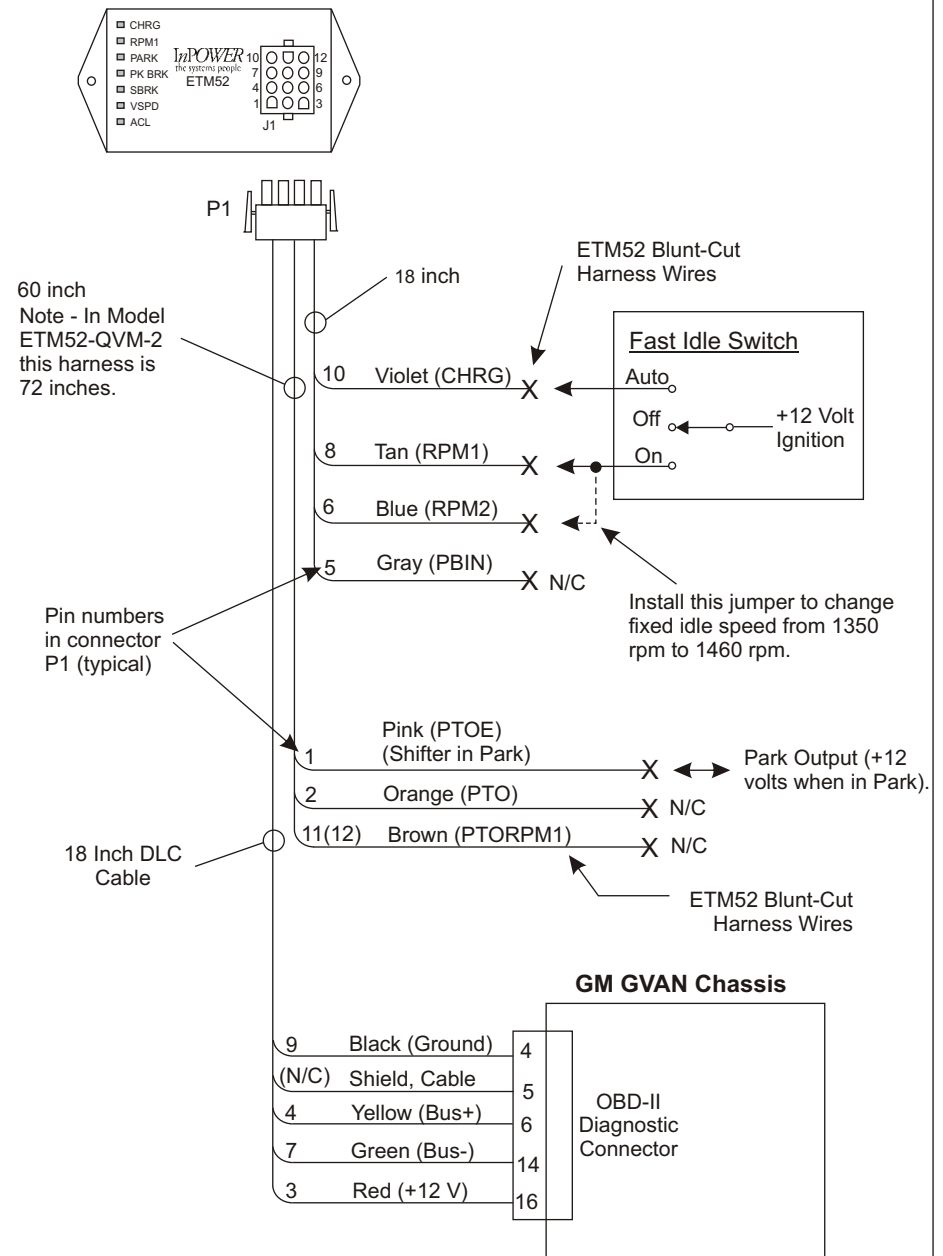

D. Installation - Chevy & GMC Chassis, Continued

6. GM Park Brake Switch Sense Wiring

On Chevy and GMC C4500 and C5500 chassis it is necessary to connect the gray wire in the ETM52 wiring harness to the parking brake switch. Depending on the chassis, this may be a foot operated brake or a hand brake on the center console. Wire into the Light Blue wire as shown in the wiring diagram on page 9.

7. GM PTO Input Wiring

Note - This procedure is required on vehicles that will operate in temperatures under 15° F. On Chevy and GMC C4500 and C5500 chassis it is necessary to wire into the GM PTO wire behind the dash. First locate the dash-mounted PTO Switch (or High Idle Switch). Remove the switch panel to expose the harness/connector on the rear and splice into the Green wire. If there is no switch installed on the dash locate the harness/connector that would plug into the switch (located behind the switch panel). On the switch harness/connector locate the wire that goes to the EMC PTO Input. This will be a Green Wire. Now splice the orange (PTO) blunt-cut wire in the ETM52 wiring harness into this wire.

This completes the GM Installation portion of the manual.

FORD E-SERIES GAS WIRING DIAGRAM

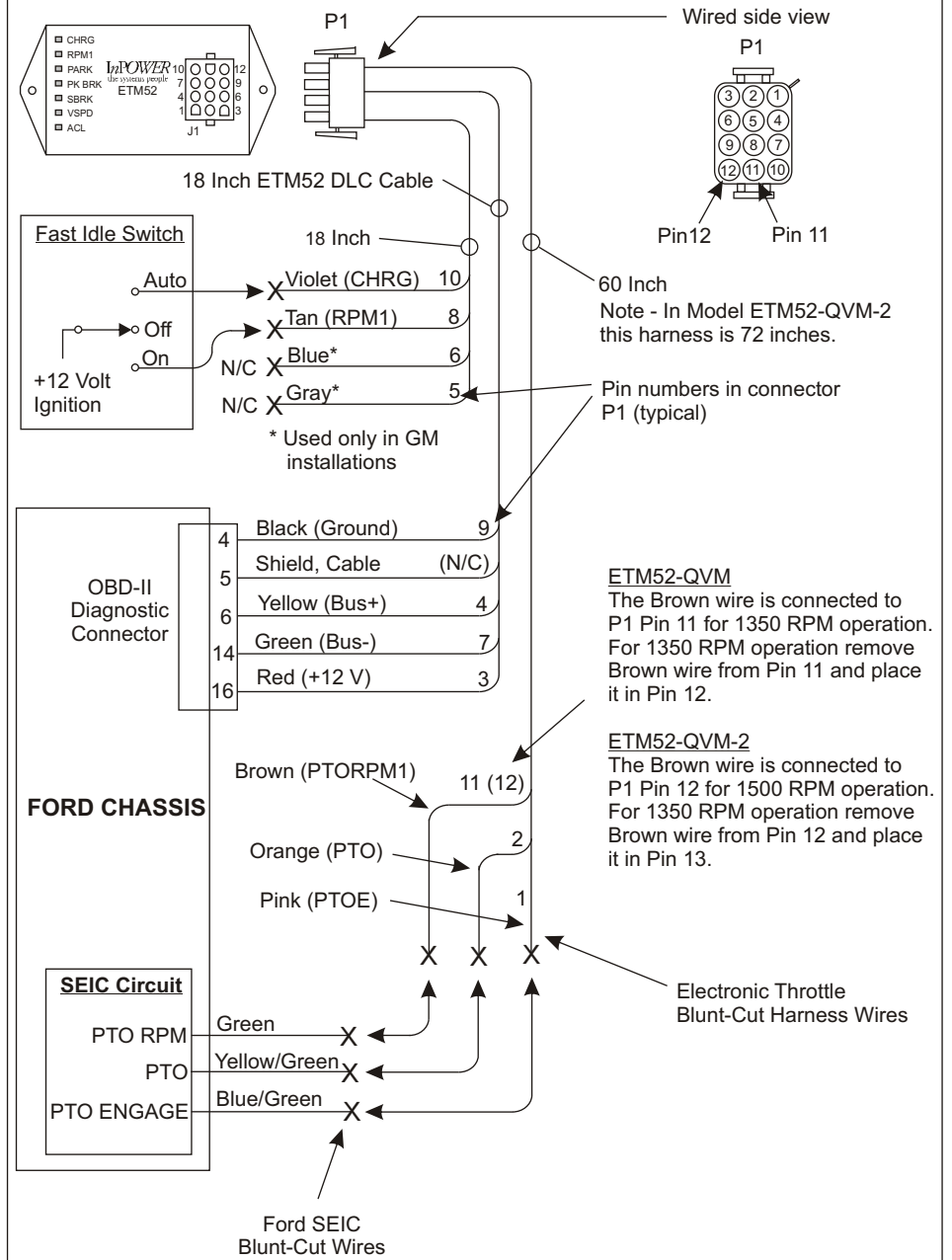

FORD E-SERIES DIESEL WIRING DIAGRAM

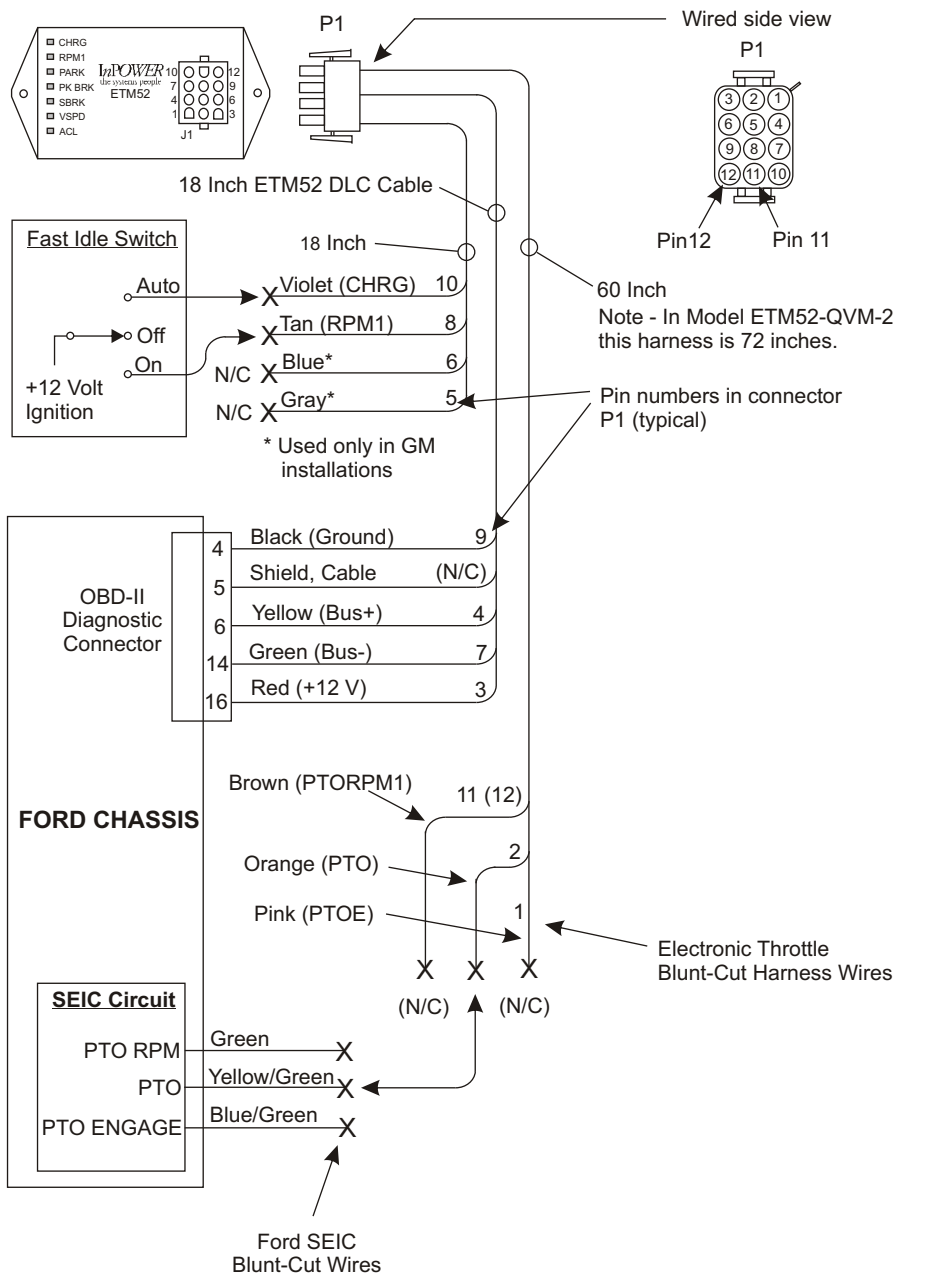

D. Installation - Chevy & GMC Chassis

1. Getting Started

The recommended location for the ETM52 system is under the dash due to the proximity of the wiring connections and cable length. **The unit should not be located in the engine compartment, or any location that is not protected. Do not lengthen the DLC Cable.**

2. Mount the Electronic Throttle Module

Disconnect the battery before making any connections. Mount the electronic throttle module under the dash using the two mounting holes. Ensure that you have sufficient distance to install the 18 inch long DLC cable.

3. Install the Wire Harness

Plug the 12-pin connector of the wiring harness into the ETM52 module. Route the DLC cable to the OBDII Data Link Connector and plug it in. The OBDII connector is usually located on the lower part of the dash on the driver's side. Using a cable tie, secure the plug to the OBDII connector so that it will not vibrate out. We recommend that you route the DLC cable back across the bottom of the plug/connector, and loop the cable tie around the plug, socket and cable, thereby keeping the cable out of the way. Also ensure that the entire cable is routed and secured to keep it out of the way. Connect the wiring harness blunt-cut wires to the mode switch (not supplied with ETM52) and to the required chassis connection as shown in the wiring diagrams.

4. Install the Fast Idle Switch

The ETM52 system provides two modes of fast idle control: Automatic and Fixed Speed. The typical installation approach is to use a three-position driver's switch with an *Auto*, *Off* and *On* position. However, these two control modes can be configured differently. For example, you might desire just an Automatic function activated by an On-Off switch. Or a fixed speed fast idle function activated by another vehicle circuit.

Prior to installing the three-position Fast Idle Switch review the GM wiring diagrams on pages 9 and 10. Mount the switch in a convenient location. Locate the ETM52 wiring harness 18 inch long group of blunt-cut wires (Violet, Tan, Blue and Gray). Wire the Violet blunt-cut wire to the Auto position and the Tan wire to the On position of the Fast Idle Switch. Wire the Fast Idle Switch common position to a +12 volt ignition circuit (+12 volts when the ignition switch is on).

The Fixed Speed mode for GM GVan and C4500/C5500 installations is 1350 rpm. This speed can be changed to 1460 rpm by the following procedure. Locate the Blue wire in the ETM52 wiring harness and combine it with the Tan RPM1 wire so the on switch provides +12 volt ignition to both wires.

5. GM Chassis Park Output Wiring

The ETM52 provides a transmission Park position output for use with InPower model ITM122 and ITM123 interlock systems on Chevy and GMC chassis. This Park wire is the pink blunt-cut wire in the ETM52 wire harness. Connect it to the Park input in the interlock system.