

OWNERS MANUAL

InPower Model ITM124 Platform Lift Interlock 2009-2010 Ford E-Series Vehicles

Contents

1. Introduction	1
2. Product Description	1
3. Installation Procedures	1
4. System Circuit Diagrams	2
5. Wiring Instructions	4
6. Interlock System Operation.....	5
7. System Troubleshooting	6
8. Mechanical Drawings.....	6

1. Introduction

This product is intended for installation in 2009-2010 Ford E-Series chassis with FMVSS compliant, public use platform lifts manufactured by The Braun Corporation, Ricon Corporation or Maxon Mobility. If another type of lift is to be used, contact the lift manufacturer to determine compatibility.

This interlock system is designed to meet the requirements of FMVSS 403/404 and must be installed in accordance with the lift manufacturer's instructions. The installer must be trained and skilled in installing FMVSS compliant lift systems. The installation must also comply with SAE (Society of Automotive Engineers) and Ford Motor Company electrical wiring procedures.

2. Product Description

The ITM124 interlock system consists of a control module and chassis interface wiring harness. It contains one connector for interfacing to the chassis interface wiring harness. It also contains five diagnostic LED indicators to aid in system troubleshooting. The chassis interface harness contains two "plug and play" tee-cables that connect to the parking brake switch and shift lock solenoid (located under the dash), as well as blunt-cut wires for interfacing to the platform lift system, door switch and +12 volt power source.

3. Installation Procedures

3.1 Safety Precautions



WARNING

This interlock product has been designed and manufactured to meet the intended application requirements and specifications. Any modifications to the product or to the installation procedure can be dangerous and will void InPower's warranty.

- Read and understand the instructions in this manual and other manuals before starting the installation.
- Make sure that the vehicle battery power is disconnected during installation of the Interlock and lift systems.
- Reconnect the battery when the system installation is complete.
- Wear appropriate safety equipment, such as protective eyeglasses, face shield and clothing when installing equipment and handling the battery.
- Be careful when working near a battery. Make sure that the area is well ventilated and that there are no flames near the battery. Never lay objects on the battery that can short the terminals together. If battery acid gets in your eyes, immediately seek first aid. If acid gets on your skin, immediately wash it off with soap and water.

3.2 Getting Started

This manual provides instructions for installing the InPower Model ITM124 Interlock System in a 2009-2010 Ford E-Series chassis with a FMVSS compliant, public use (commercial) platform lift. It is important that you follow these instructions carefully and contact InPower if you need assistance or more information. Note that product technical documents are available on InPower's web site.

! WARNING

Before installing and operating this interlock system, read and understand the lift manufacturer's safety, operating and installation instructions.

This interlock system installation requires additional parts and materials that are not supplied with the interlock product. Identify all required parts before starting the installation and ensure that these items are the correct type and quality.

Inspect the interlock product and all other components for damage before starting the installation. Do not perform the installation if any problems exist.

Determine the type of interlock interface required for the platform lift. This interlock system provides a +12 volt @ 2 amps *Lift Enable* output to allow the platform lift to be operated. If the lift system is not compatible with this interface signal you must take the necessary actions to adapt the lift system interface to the interlock system's interface. Refer to the lift manufacturer's installation instructions for further details.

The recommended mounting location for the ITM124 interlock module is under the dash, to the left of the steering column due to the proximity of the wiring connections. **The unit must not be located in the engine compartment or any location that is not protected from the environment.**

4. System Circuit Diagrams

The following pages show the individual circuits that need to be wired. The following section, 5. *Wiring Instructions*, describes how to wire these circuits.

Interlock System Layout

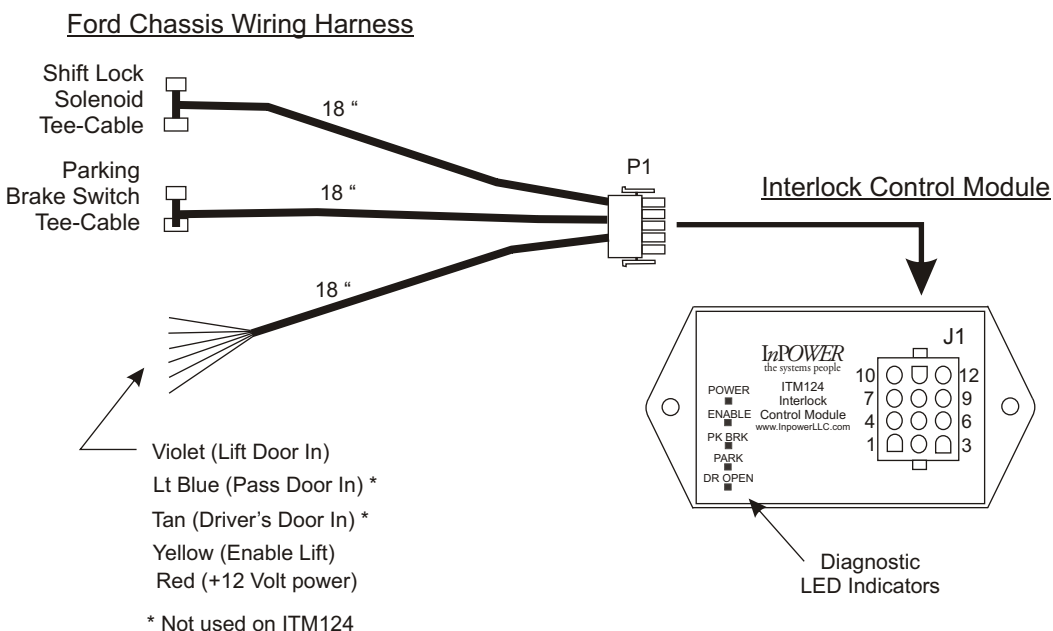

4. System Circuit Diagrams (Cont'd)

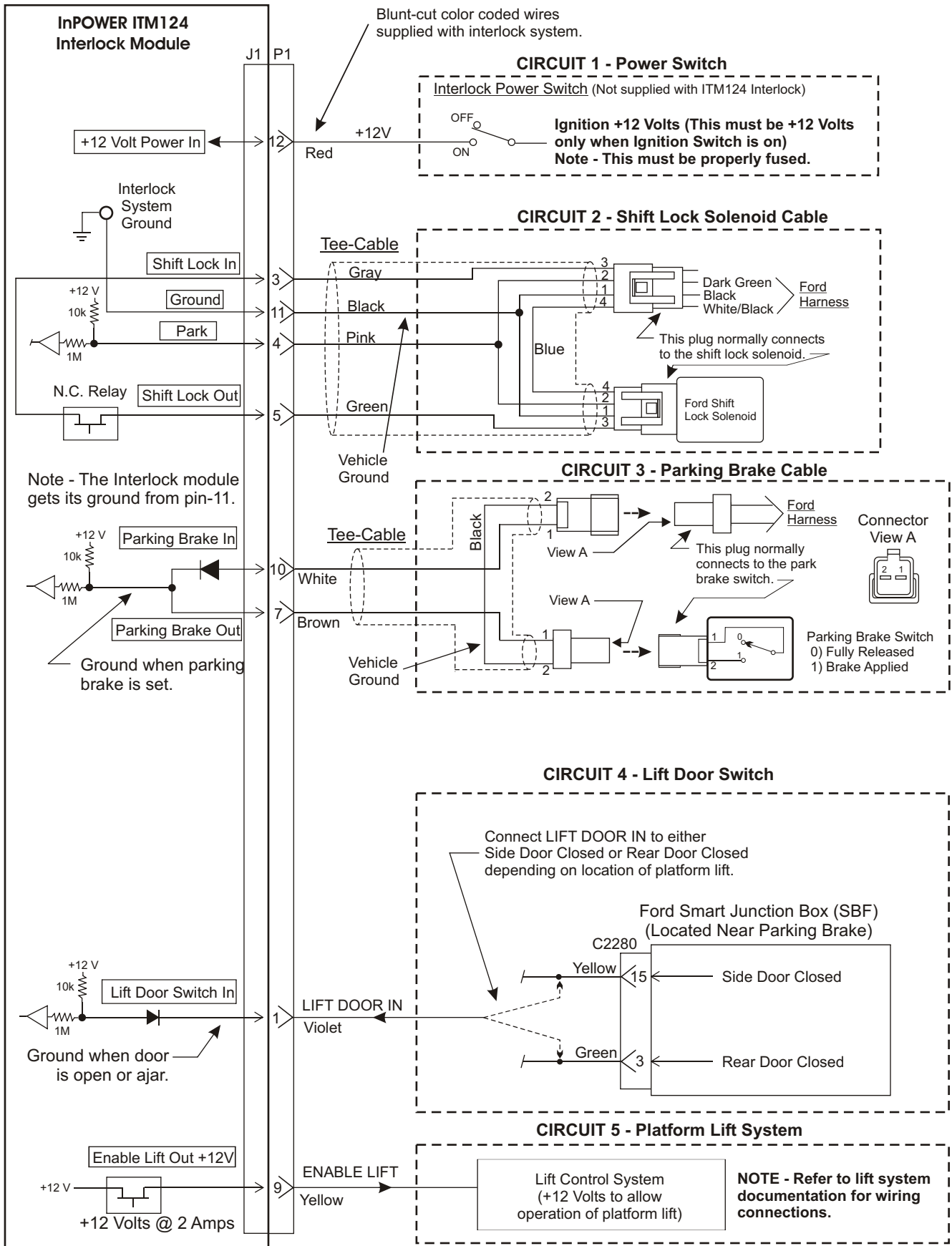

5. Wiring Instructions

Circuit 1 Wiring (Interlock System Power Switch)

The installer must supply a two-position On-Off Interlock power switch capable of handling the current of the Lift Enable output. This switch may be mounted on the dash at a convenient location. NOTE - An alternative method is to wire the interlock module power input directly to a +12 volt fused power source that is powered by the Ignition Switch, and delete the Interlock Power Switch.

1. Mount the Interlock Power Switch.
2. Wire the “common” side of the Power On/Off switch to a properly fused +12 volt ignition switch source (**powered when the ignition switch is On**). Refer to the Ford documentation for location of customer access ignition circuits.
3. Wire the “On” position side of the switch to the Red harness wire that goes to pin 12 on the interlock module.
4. When complete, you should have +12 volt fused power on the interlock module pin 12 when the ignition switch is On and the Interlock Power Switch is On.

NOTE - Do not power the interlock system directly from the Battery or any power source that is not fused and turned off with the ignition switch.



WARNING

Make sure that the vehicle battery power is disconnected during installation of the Interlock and lift system. Reconnect the battery when the system installation is complete.

Circuit 2 Wiring (Shift Lock Solenoid Cable)

1. Locate the shift lock solenoid that is on the bottom left of the steering column behind the dash panel. It has a four-wire harness plugged into it.
2. Remove the harness plug from the solenoid assembly.
3. Install the tee-cable supplied with the interlock between the solenoid connector and the harness plug that you removed from the solenoid. When complete, the interlock tee-cable will be connected to the Ford harness plug and the shift lock solenoid as shown in Circuit # 2 diagram.

Circuit 3 Wiring (Parking Brake Switch Cable)

1. Locate the Parking Brake Switch connector C2015 that is near the parking brake pedal assembly. It has a two-wire harness plugged into it.
2. Remove the harness plug from the switch connector.
3. Install the tee-cable supplied with the interlock wiring harness between the parking brake switch connector and the harness plug that you removed from the parking brake switch connector.
4. When complete, the interlock tee-connector will be connected to the Ford harness plug and to the parking brake switch connector as shown in Circuit # 3 diagram.

Circuit 4 (Lift Door Switch)

Wire the switch as shown in the Circuit # 4 diagram. You will need to connect the Violet blunt-cut wire that is in pin 1 on the interlock connector P1 to a wire in the harness on connector C2280 the Ford *Smart Junction Box* located near the parking brake. If the platform lift is located in the rear, wire the interlock Violet wire to Green wire on pin 3 on connector C2280. If the platform lift is located on the side of the vehicle wire the interlock Violet wire to the Yellow wire on pin 15 of connector C2280. Be sure to carefully tap into the Ford harness wire and do not break continuity of the original Ford harness wire.

Circuit 5 Wiring (Platform Lift)

Review the platform lift installation manual and determine how to wire the ITM124 interlock system to the following lift interface connections:

Enable Lift - This is an **input** to the lift system. When at +12 volts, the platform lift can be operated. Install a wire from the platform lift's *Enable Lift* input to the ITM124 Yellow blunt-cut wire That goes to pin 9 on the Interlock module.

Note - The ITM124 will supply a +12 volt @ 2 amp output to allow operation of the lift. Verify that this is the correct polarity for the platform lift.

5. Wiring Instructions (Continued)

Circuit 5 Wiring (Platform Lift) - Continued

The following diagrams show the wiring interface of typical platform lift systems. **Be sure to verify the exact wiring interface for the lift system that you have.**

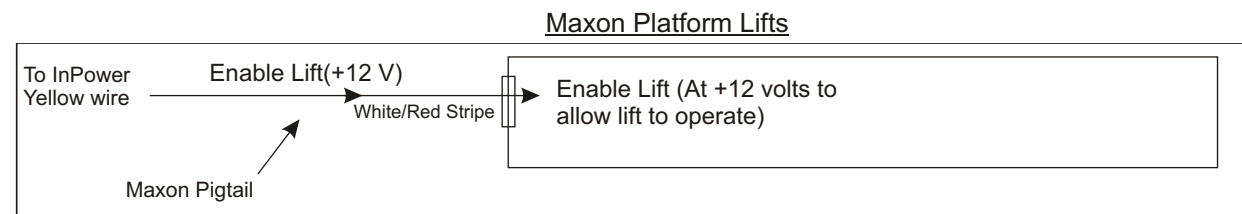
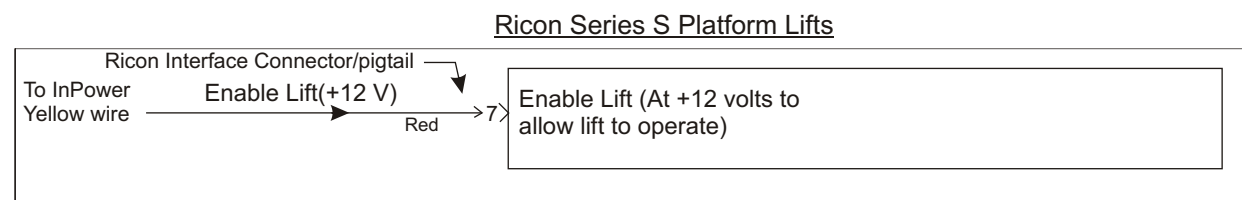
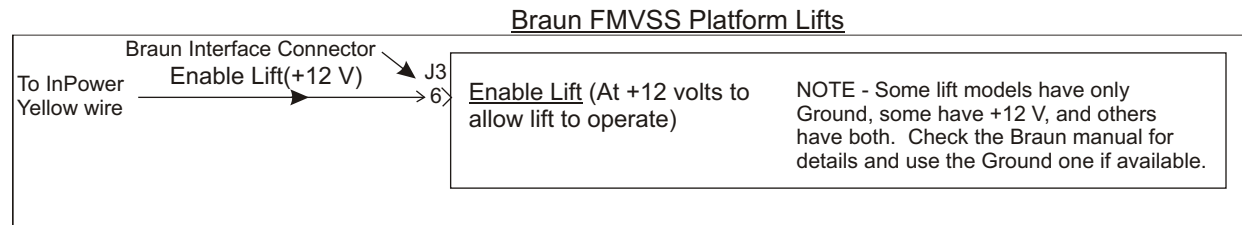

6. Interlock System Operation

The interlock system is powered from the Interlock Power Switch and the Ignition Switch when they are both in the On position. The following is the interlock system sequence of operation:

- Step 1 - Ignition switch on and engine running.
- Step 2 - Press service brake and place shifter in Park.
- Step 3 - Set parking brake.
- Step 4 - Open lift door.
 - The Door Open diagnostic LED indicator will activate
 - Shift Lock will activate
 - Lift Enable will activate allowing operation of platform lift.
- Step 5 - The platform lift may now be operated (Refer to the platform lift operating instructions).
Note - During the Lift Enable sequence, if the parking brake is released the Lift Enable will be deactivated, preventing lift operation.
- Step 6 - When the lift cycle is completed return the lift to its fully stowed position.
- Step 7 - Close the lift door.
- Step 8 - Release parking brake. When released, the shift lock will be automatically released.
- Step 9 - The cycle is now complete and the vehicle can be taken out of Park and driven.

Note: The Lift Door Open output (+12 v @ 2 amps) is activated whenever the door is open, independent of other interlock inputs.

7. System Troubleshooting

If there is a problem with system operation, there is a very high probability that the control module has: A) either lost its ground or +12 volt power source, or B) that one or more of its inputs are not being actuated by the remote switch (e.g., Lift Door Switch). Most troubles are related to wiring problems, or switches either failing or becoming out of adjustment.

Troubleshooting Procedure:

- Step 1 - Determine if the control module is powered. If the LEDs on the control module are illuminated you have power. If none are illuminated, check the +12 volt supply on +12V terminal with a voltmeter. Also check that the module is getting a good ground on pin 11 of connector J1.
- Step 2 - If the ground and power are correct, first reset the interlock system by turning off its power. Then, step through the operating sequence as described in Section 6. *Interlock System Operation*, and note the status of the green and red LED indicators on the control module. Pay particular attention to the inputs LEDs such as the lift door switch input. Verify that the input status LEDs agree with the switch positions.

The interlock control module contains six diagnostic LED indicators to aid in system troubleshooting. These indicators show the status of input and output signals of the control module. These diagnostic indicators are located on the connector side of the module.

System Diagnostic LED Indicators (Located on the Control Module)

- POWER (Red) On when +12 volt power is applied to module. The LED will go out if the ENABLE output current exceeds 2 amps.
- PK BRK (Red) On when the park brake is set.
- PARK (Red) On when the transmission is in the Park position.
- ENABL (Red) On when the interlock allows the platform lift to operate.
- DR OPEN (Red) On when the platform lift door is ajar or open (not fully closed).

8. Mechanical Drawing

Model ITM124 Control Module

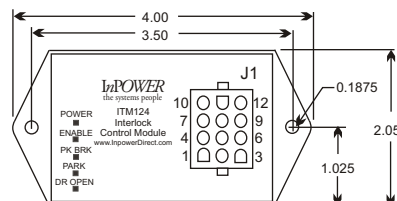

All dimensions in inches. Not to scale.

9. Reference Information

Ford Motor Company

Truck Body Builder Advisory Service
Product Development Center
MD 410
PO Box 2053
Dearborn, MI 48121-2053
1-877-840-4338
www.fleet.ford.com/truckbbas/index.htm
bbasqa@ford.com

Ricon Corporation

7900 Nelson Road
Panorama City, CA 91402
(818) 267-3038
(800) 322-2884
www.riconcorp.com

The Braun Corporation

631 West 11th Street
Winamac, IN 46966
(574) 946-6153
(800) 946-6158
www.braunlift.com

Maxon Lift Corp.

11921 Slauson Avenue
Sante Fe Springs, CA 90670
(562) 464-0099
(800) 227-4116
www.maxonlift.com

InPOWER
the systems people

© Copyright 2008 InPower LLC

InPOWER LLC
3555 Africa Road
Galena, Ohio 43021 U.S.A.
(866)548-0965
www.InPowerLLC.com

Page
6 of 6

ITM124 Owners Manual

Document: OM-112
Date: March 8, 2010

Version Code: A
Date: March 8, 2010