

OWNERS MANUAL

Model ETM61 Electronic Throttle Module for Chevy/GMC Gas & Diesel Engines with Manual Transmissions



A. Introduction

The InPower Model ETM61 electronic throttle module is designed for installation in the following 2003/04 Chevy and GMC truck, van and sport utility vehicles:

4.8 L *Vortec* Gas with Manual Transmission
5.3 L *Vortec* Gas with Manual Transmission
6.0 L *Vortec* Gas with Manual Transmission

8.1 L *Vortec* Gas with Manual Transmission
6.6 L *Duramax* Diesel with Manual Transmission

Five modes of fast idle control are provided, including: three fast idle preset speeds (user adjustable), a variable speed input (remote variable resistor), and *Charge Protect*, which will advance the engine speed from 680 rpm until it senses sufficient voltage at the battery to maintain its charge (1700 rpm maximum).

The ETM61 electronic throttle installation requires customer supplied control wiring to select the required mode of operation. This wiring connects to the ETM61 module via 0.25 inch Faston terminals. The ETM61 system is supplied with a three foot data cable. This cable contains an 16-pin connector at one end and 0.25 inch Faston terminals at the other end. The Faston terminals will connect at the ETM61 module and the 16-pin connector plug will attach to the vehicle's OBDII (On Board Diagnostic) data link connector (DLC). The DLC is usually located at the lower part of the dash on the driver's side.

B. Operation

When the vehicle is parked and **Chassis Ready Conditions** are satisfied the engine speed may be controlled by one of the five available modes (three preset speeds, *Charge Protect*, or variable rpm). The preset speed may be adjusted by three calibration potentiometers on the top of the ETM61 module.

Chassis Ready Conditions:

1. Parking brake is set
2. Gear shift in NEUTRAL
3. Foot is off service brake
4. Foot is off clutch
5. Foot is off the accelerator pedal
6. Vehicle is stationary (no speed)
7. Engine is started and idling

Modes Of Operation

1. Three Preset RPM High Idle Modes:
Function: Increase idle to a preset rpm value
Terminals: RPM1, RPM2, RPM3
Activation: Apply +12 V to terminal
Range of Calibration: 680 to 2000 rpm
Type of Adjustment: Internal potentiometers

B. Operation (Cont'd)

2. Charge Protect Mode:

Function: Varies rpm to maintain battery charge voltage
Control Terminal: CHRG
Activation: Apply +12V to CHRG terminal
RPM Range: 680 to 1700 rpm

3. Variable RPM Mode:

Function: Varies rpm as a function of voltage on VRPM
Terminal: VRPM
Adjustment: 10K Ohm potentiometer between the VRPM terminal and ground
Enable: Turn potentiometer down to zero resistance, then slowly increase until desired rpm is reached
Disengage: Turn potentiometer down to zero and rpm will drop to standard idle speed
RPM Range: 680 to 2000 rpm

4. Mode Priorities:

A mode priority selection scheme is provided that will eliminate conflicts if more than one mode is selected at a time. In the case of one or more modes being selected, the following priorities will be established:

RPM1 Highest - Will override all other modes
RPM2 Second - Will override lower modes
RPM3 Third - Will override lower modes
Charge Protect Forth - Will override lower modes
Variable RPM Lowest - Will only activate when other modes are off

NOTES:

1. The ETM61 system must be initialized anytime that the DLC cable is disconnected from the OBDII connector. To initialize the system, first plug in the DLC cable, shut the Ignition Switch Off, then back On, then start the engine.

2. On GM gas engine vehicles the PCM engine computer will cause the engine speed to momentarily drop back to normal idle speed every time the air conditioner pump cycles either on or off. On ETM61 units with Revision A (identified as "ETM-61A") the A/C function will be disabled when in fast idle mode to prevent this on/off cycling.

Status Indicators

A 10 segment LED provides status and problem detection information. Refer to the following table for coding of these functions.

LED	Status	Indication
BUSS	On Solid	Module ON and functioning
BUSS	Flashing	Module ON, but a problem was detected
GEAR	On Solid	Clutch pedal released
GEAR	Flashing	Clutch pedal not released
PK BRK	On Solid	Park Brake set
PK BRK	Flashing	Park Brake not set
SR BRK	On Solid	Service Brake set
SR BRK	Flashing	Service Brake not set
VSPEED	On Solid	Vehicle is stationary
VSPEED	Flashing	Vehicle is moving
RPM1	On Solid	RPM1 mode selected, engine at fast idle
RPM1	Flashing	RPM1 mode selected, engine not at fast idle (Interlocks not satisfied*)
RPM2	On Solid	RPM2 mode selected, engine at fast idle
RPM2	Flashing	RPM2 mode selected, engine not at fast idle (Interlocks not satisfied*)
RPM3	On Solid	RPM3 mode selected, engine at fast idle
RPM3	Flashing	RPM3 mode selected, engine not at fast idle (Interlocks not satisfied*)
CHRГ	On Solid	CHRГ mode selected, engine at fast idle
CHRГ	Flashing	CHRГ mode selected, engine not at fast idle (Interlocks not satisfied*)
VRMP	Off	VRPM terminal at zero resistance value (engine at idle)
VRPM	On Solid	VRPM terminal increases above threshold level (0.6v) and engine speed increases accordingly.
VRPM	Flashing	VRPM terminal increases above threshold level (0.6v) but engine does not respond with elevated speed.

* See *Chassis Ready Conditions* on page 1 for required conditions to satisfy interlocks.

C. Installation

1. Getting Started

The recommended location for the ETM61 system is under the dash due to the proximity of the wiring connections and cable length. **The unit should not be located in the engine compartment, or any location that is not protected.** You will need a crimping tool for the 0.25 inch Faston (blade) terminals, and a wire stripping tool. Be sure to follow the crimping tool instructions for the proper wire size and terminals.

2. Mount the ETM61 Module

Mount the ETM61 module under the dash using the two mounting holes. Ensure that you have sufficient distance to install the 36 inch long DLC cable.

3. Install the DLC Cable

Connect the three Faston terminals on the DLC cable to the ETM61 module terminals (Black wire to GND terminal, Red wire to +12V terminal, and White wire to BUSS terminal). Route the cable to the OBDII (On Board Diagnostic) Data Link Connector and plug it in. The OBDII connector will be located on the lower part of the dash on the driver's side. Using a cable tie, secure the plug to the OBDII connector so that it will not vibrate out. We recommend that you route the cable of the plug back across the bottom of the connector and loop the cable tie around the plug, socket and cable, thereby keeping the cable out of the way. Also ensure that the entire cable is routed and secured to keep it out of the way.

4. Wire the Mode Selection Controls

The following wiring is required by the customer to select the operating modes required to run the ETM61 system. You will need to supply contact closures such as a toggle switch or relay contact to supply +12 volts at the ETM61 terminals for the three preset rpm modes and the Charge Protect mode. **It is important that the +12 volts used to feed the mode select terminals is from the Ignition Switch power source. That is, it must be +12 volts when the Ignition Switch is On, and zero volts when the Ignition Switch is Off.**

A. Preset Speed Modes

If you are using any of the three preset speed modes (RPM1, RPM2 or RPM3) you will need to supply a separate contact closure to each preset terminal. The contacts need to supply +12 volts (Ignition Switch power) to activate the preset modes.

B. Charge Protect Mode

If you are using the Charge Protect mode you will need to supply a contact closure between the CHRGM terminal on the ETM61 and the +12 V Ignition Switch power.

C. Variable RPM Mode

If you are using the Variable RPM mode you will need to supply a 10,000 ohm variable resistor (potentiometer) between the VRPM terminal on the ETM61 module and ground. We recommend a ten-turn potentiometer.

D. Setup and Calibration

The only calibration required is to select each of the three preset rpm modes (RPM1, RPM2 & RPM3) and adjust the three respective calibration potentiometers on the top of the ETM61 module to the desired speed (680 through 2,000 RPM). Adjustments can be made with a 1/16" (1.6 mm) or smaller screw driver. Each potentiometer is a ten turn module, with an increase or decrease of about 300 rpms per complete turn.

E. Wiring Diagram

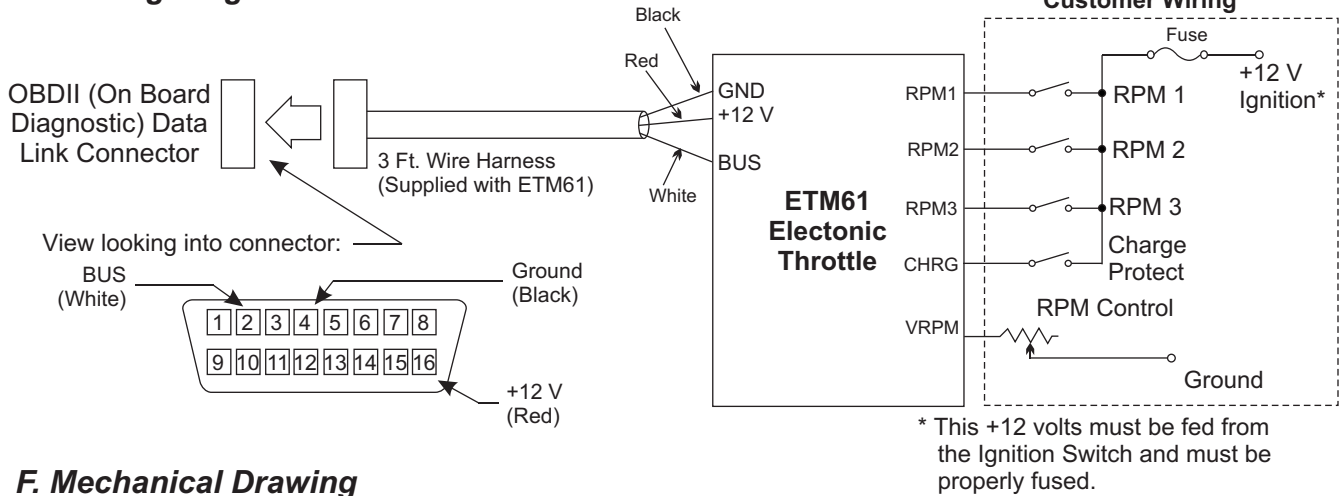

F. Mechanical Drawing

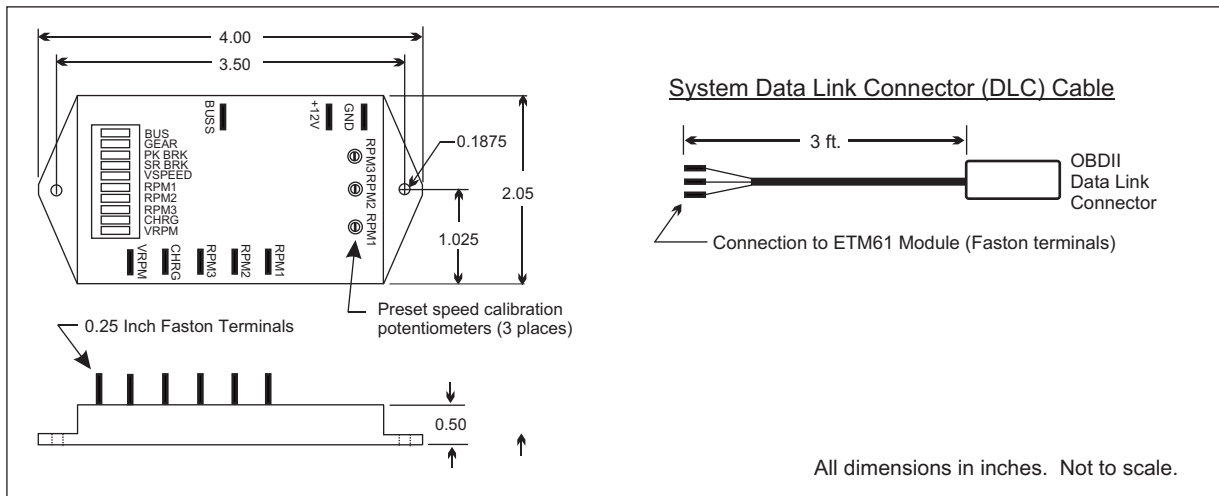

G. Specifications

Electrical

Input Voltage (+12V Terminal): 8 to 16 volts
 Input Current (+12V Terminal): 30 mA

Mechanical

Weight: 0.17 lbs
 Connections: Faston 0.25 inch terminals
 Case Material: Cyolac thermoplastic (UL 94VO)
 Encapsulation Material: Epoxy potting compound, resistant to most fuels, oils, acids, and cleaning Agents.

H. Customer Support

Technical Support

For product support, contact InPower at 740-548-0965 or 866-548-0965. Product bulletins and owner's manuals are available on our web site: www.InPowerDirect.com.

Warranty

InPOWER LLC warrants its products to be free from defects in material and workmanship under normal use, care and maintenance for a period of two (2) years from the date of shipment. Please see www.inpowerdirect.com/warranty.htm for specifics or call 866-548-0965 for a copy of our warranty policy.

Customer Evaluation

InPower wants to ensure total customer satisfaction. Please download a product evaluation form at www.InPowerDirect.com/Customer_evaluation.htm or call us toll free at 866-548-0965 to be sent a form by mail.