

OWNERS MANUAL

InPower Model ITM110C Wheel Chair Platform Lift Interlock

For Installation In 2005/06 Ford E-Series Vans



1. Introduction

This document describes the installation procedure for the InPower Model ITM110C Interlock System. This product is intended for installation on 2005/06 Ford E-Series vans with FMVSS (Federal Motor Vehicle Safety Standards) compliant, public use platform lifts manufactured by The Braun Corporation, Ricon Corporation, or Maxon Mobility. If another type of lift is to be used refer to the lift manufacturer's instructions, or contact the lift manufacturer to determine its compatibility.

This interlock system is designed to meet the requirements of FMVSS 403 & 404 and therefore must be installed in accordance with the platform lift manufacturer's instructions. Standard 403 describes the requirements of the platform lift, and Standard 404 describes the certification requirements of the platform lift/interlock system installation by the vehicle manufacturer. The installer shall be trained and skilled in installing FMVSS compliant platform lifts and vehicle interlock systems. Installation procedures shall comply with SAE (Society of Automotive Engineers) and Ford Motor Company electrical wiring procedures.

2. System Description

The ITM110C Interlock System is comprised of the interlock control module and the interface wiring harness. The system is designed to be installed on current production Ford E-Series vans for public use platform lift applications.

Interlock Control Module

The interlock module is a completely solid state design that performs the FMVSS 403 platform lift vehicle safety interlocks.

Interface Wiring Harness

The wiring harness performs the function of connecting the interlock control module to the vehicle wiring, the platform lift, and other devices. The harness is designed to minimize the need to cut and splice into the OEM chassis harness. This provides a "plug and play" capability that will reduce installation time and increase reliability.

2. System Description (Cont'd)

Platform Lift Door

The interlock system monitors the lift door switch to ensure that the lift door is open before setting the shift lock and enabling operation of the platform lift.

Platform Lift Interface

The ITM110C interlock system is designed to interface directly to FMVSS compliant platform lifts manufactured by The Braun Corporation, Ricon Corporation, and Maxon Mobility. The system provides a *Lift Enable* output that is +12 volts (@ 8 amps) that will enable the operation of the lift. It also requires a +12 volt signal from the lift to indicate that the platform lift is in the fully stowed position.

3. Interlock System Operation

The Interlock System is powered from the ignition switch in the On position. Some installations may provide a separate Interlock System power switch.

The following is the normal sequence of operation for operating the platform lift.

- Step 1 - With the interlock system power switch on and engine running, place the transmission in PARK.
- Step 2 - Set the parking brake.
- Step 3 - Open the Lift Door. When opened, the *Lift Enable* output will be set to allow operation of the lift, and the transmission shift lock will be set to prevent the transmission from being taken out of PARK.
- Step 4 - The platform lift may now be operated. (Refer to platform lift operating instructions).
NOTE - During the *Lift Enable* sequence, if the parking brake is released the *Lift Enable* will be deactivated, preventing lift operation.
- Step 5 - When the lift operation is complete the lift should be returned to its fully stowed position.
- Step 6 - Close the lift door.
- Step 7 - Release the parking brake. When the parking brake is released the *Shift Lock* will be automatically released.
- Step 8 - The cycle is now complete and the vehicle can be taken out of PARK and can be driven.

4. System Diagram

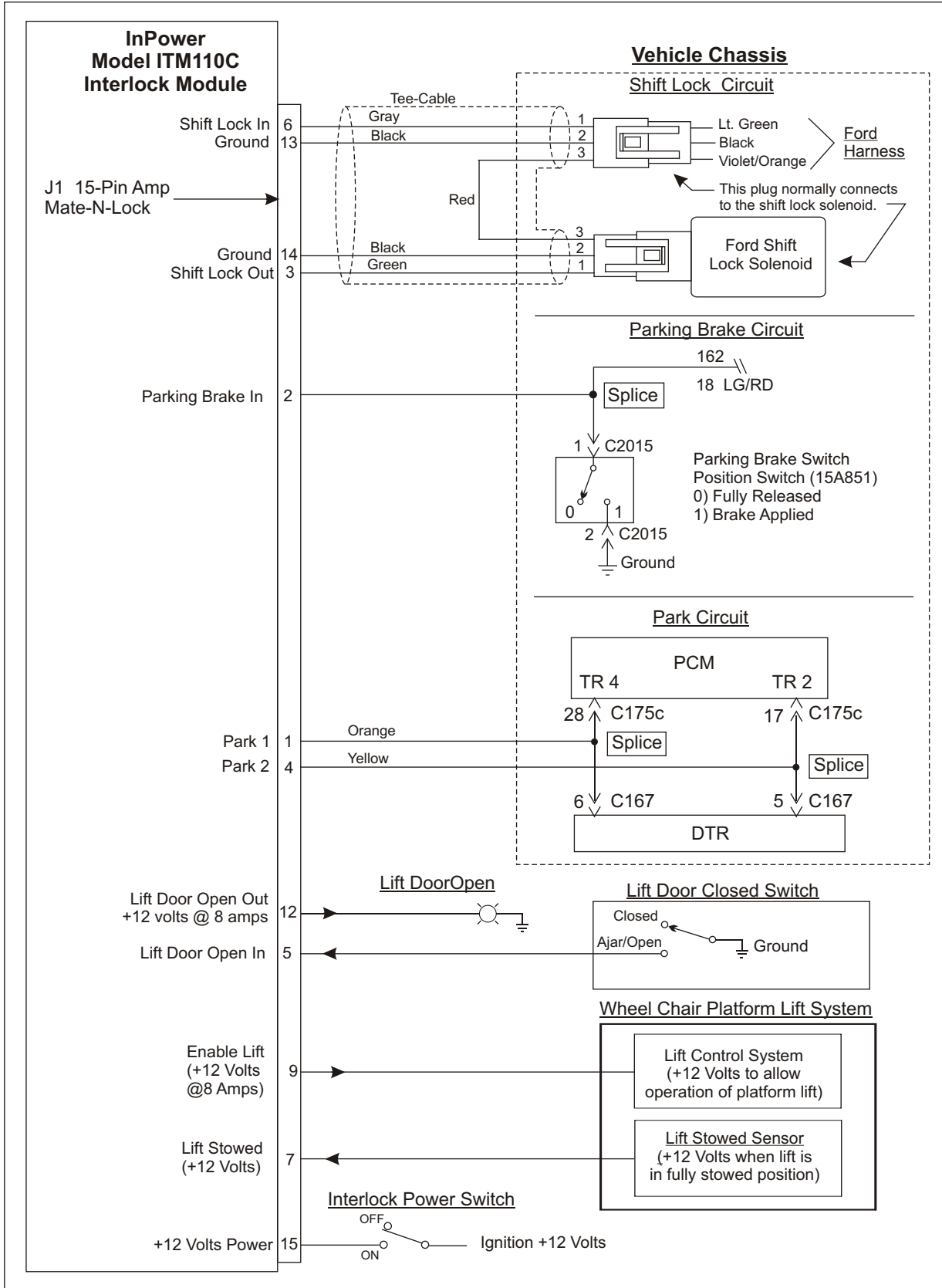

5. Specifications

Module Inputs

Power Input: +8 to +16 Vdc @ 16 amps
Ground: Chassis Ground/Battery Negative (via Ford harness)
Lift Door Closed: Ground when door is not closed

Module Outputs

Shift Lock Solenoid: Normally closed solid state relay for solenoid control; opens to lock park position
Lift Enable: +12 Vdc @ 8 amps to enable lift operation
Door Open Remote Lamp: +12 Vdc @ 8 amps when lift door is open (Flash rate = 60 per minute)

Mechanical

Weight: 0.15 lbs
Case Material: Anodized Aluminum
Operating Temperature: -40° C to +85° C
Storage Temperature: -50° C to +85° C
Connector System: Tyco/Amp Universal Mate-N-Lok (15-pin and 3-pin)

6. Installation Procedure

6.1 Safety Precautions



WARNING

This interlock product has been designed and manufactured to meet the intended application requirements and specifications. Any modification to the product or to the installation procedure can be dangerous and is not authorized.

Read and understand the instructions in this manual and in the other equipment manuals before starting the installation.

Make sure that the vehicle battery power is disconnected during installation of the Interlock and lift system. Reconnect the battery when the system installation is complete.

Wear appropriate safety equipment, such as protective eyeglasses, face shield and clothing when installing equipment and handling the battery.

Be careful when working near a battery. Make sure that the area is well ventilated and that there are no flames near the battery. Never lay objects on the battery that can short the terminals together. If battery acid gets in your eyes, immediately seek first aid. If acid gets on your skin, immediately wash it off with soap and water.

6.2 Getting Started

This manual provides instructions for installing the InPower model ITM110C Interlock System in a 2005/06 Ford E-Series van with a FMVSS compliant platform lift. It is important that you follow these instruction carefully and contact InPower if you need assistance or more information. You can reach InPower at:

**InPower LLC
Customer Support
740-548-0965**



WARNING

Before installing and operating this interlock system read and understand the lift manufacturer's safety, operating and installation instructions.

This interlock system requires the installer to be trained to install and work on vehicle electrical systems. We recommend that all wiring meet the SAE and Ford wiring specifications.

This interlock system installation requires additional parts and materials that are not supplied with the interlock product. Identify all required necessary parts before starting the installation and ensure that these items are the correct type and quality.

Inspect the interlock product and all other components for damage before starting the installation. Do not perform the installation if any problems exist.

6.3 Getting Started (Cont'd)

Determine the type of interlock interface required for the platform lift. This interlock system provides a +12 volt @ 8 amps *Lift Enable* output to allow the platform lift to be operated. It also requires a *Lift Stowed* signal from the lift system that is +12 volts when the lift is in the fully stowed position. If the lift system is not compatible with these two interface signals you must take the necessary actions to adapt the lift system interface to the interlock system's interface.

The recommended location for the ITM110C interlock module is under the dash, left of the steering column, due to the proximity of the wiring connections. **The unit should not be located in the engine compartment or any location that is not protected.**

The following pages show the individual circuits that need to be wired, followed by wiring instructions.

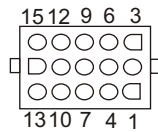

6.4 Circuit Diagrams

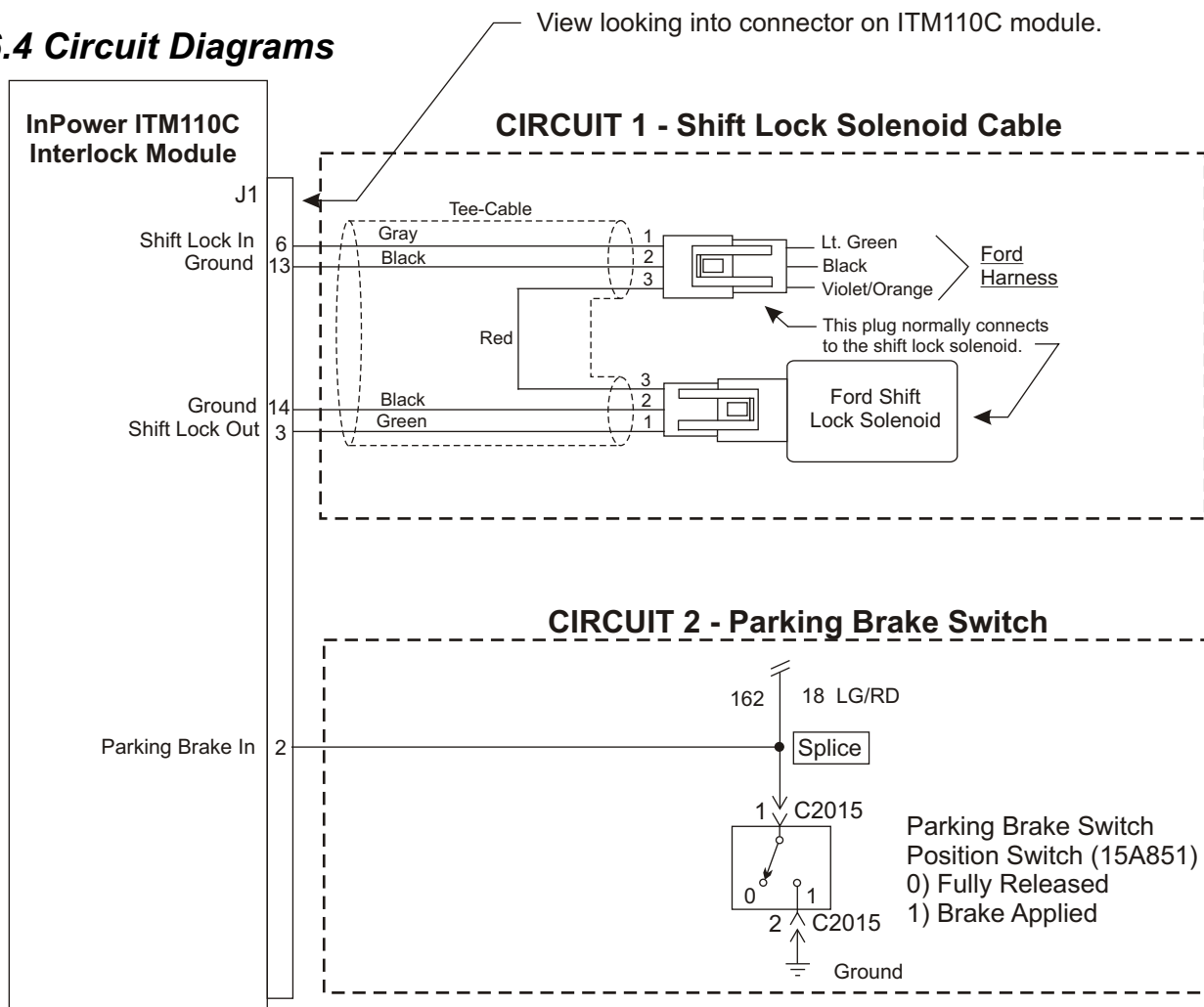

6.4 Circuit Diagrams

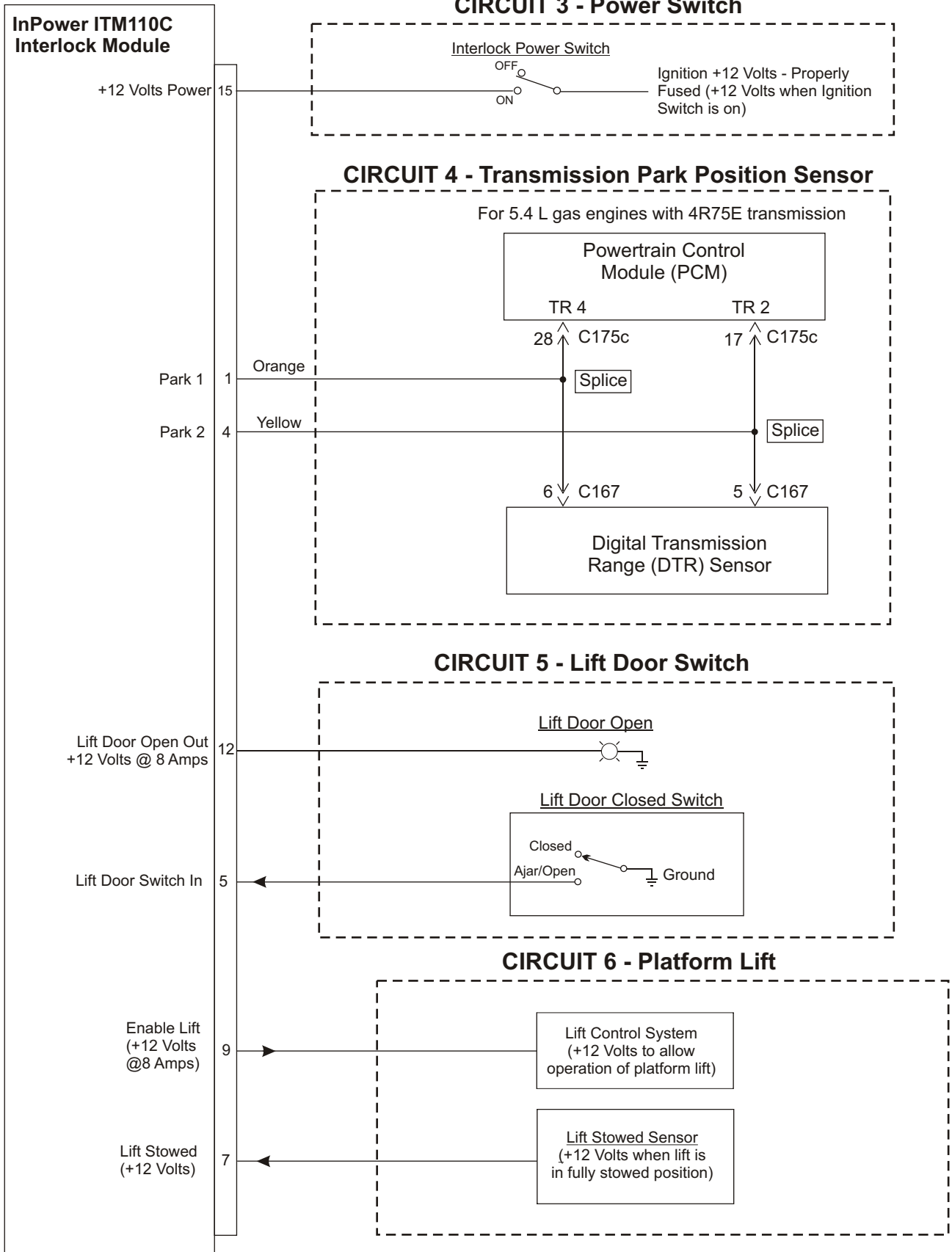

6.5 Installation Instructions



WARNING

Make sure that the vehicle battery power is disconnected during installation of the Interlock and lift system. Reconnect the battery when the system installation is complete.

Circuit 1 Wiring (Shift Lock Solenoid Cable)

1. Locate the shift lock solenoid that is on the bottom left of the steering column. It has a three wire harness plugged into it.
2. Remove the harness plug from the solenoid.
3. Install the tee-cable supplied with the interlock between the solenoid connector and the harness plug that you removed from the solenoid. When complete the interlock tee-cable will be connected to the Ford harness plug and the shift lock solenoid as shown in Circuit #1 diagram.

Circuit 2 Wiring (Parking Brake Switch)

1. Locate the Parking Brake Switch connector C2015.
2. Locate the light green/red wire (18 LG/RD) on connector pin 1.
3. Splice into this wire with the ITM110 wire harness wire that goes to pin 2 on the ITM110 Module.

Circuit 3 (Power Switch)

The installer must supply the two-position On-Off Interlock Power Switch. This switch may be mounted on the lower dash panel to the left of the steering column.

1. Mount the Interlock Power Switch.
2. Wire the common side of the switch to +12 volt ignition.
3. Wire the On position side of the switch to the harness wire that goes to pin 15 on the interlock module.
4. When complete, you should have +12 volt power on the interlock module pin 15 when the ignition switch is On and the Interlock Power Switch is On.

Circuit 4 (Transmission PARK Position Sensor)

Locate the TR 2 and TR 4 wires that go between the transmission sensor (DTR) and the Powertrain Control Module (PCM). See Circuit 5 diagram.

1. Splice into TR 4 wire and connect it to pin 1 (Orange wire) on the interlock control module.
2. Splice into TR 2 wire and connect it to pin 4 (Yellow) wire) on the interlock control module.

Circuit 5 (Lift Door Switch and Light)

You can use the Ford door switch wiring or install a new switch. The switch must be actuated when the lift door is in the fully closed position. Wire the switch as shown in the Circuit #5 diagram. The switch common must be wired to ground. The switch contact in the NOT CLOSED position is to be wired to the wire in the interlock wiring harness that goes to pin 5. When complete, the wire to the interlock control module pin 5 will be at ground when the lift door is ajar or open.

If a lift door open light is required wire the light to the Door Open Output on the interlock control module pin 12. This output supplies +12 volts @ 8 Amps. The other side of the light must be wired to ground.

Circuit 6 (Platform Lift)

Review the platform lift installation manual and determine how to connect the two required wires from the interlock. These two wires are:

1. *Lift Enable* (blunt-cut wire in the interlock harness that goes to pin-9)
2. *Lift Stowed Sensor* (blunt-cut wire in the interlock harness that goes to pin-7)

The *Lift Enable* wire from the interlock system provides +12 volts dc when it is permissible to operate the platform lift. The *Lift Stowed Sensor* is an input to the interlock system that is +12 volts when the lift is in the fully stowed position. **It is critical that these two interface wires are of the correct polarity. If in doubt, contact the platform lift manufacturer to determine the correct interface.** Wire the Yellow *Lift Enable* and Orange *Lift Stowed Sensor* interlock harness wires to the lift system.

7. Reference Information

Ford Motor

Truck Body Builder Advisory Service
Product Development Center
MD 410
PO Box 2053
Dearborn, MI 48121-2053
1-877-840-4338
[Http://www.fleet.ford.com/truckbbas/index.htm](http://www.fleet.ford.com/truckbbas/index.htm)
Bbasqa@ford.com

The Braun Corporation

631 West 11th Street
Winamac, IN 46966
(574) 946-6153
(800) 946-6158

Ricon Corporation

7900 Nelson Road
Panorama City, CA 91402
(818) 267-3038
(800) 322-2884
www.riconcorp.com

Maxon Lift Corp.

11921 Slauson Avenue
Sante Fe Springs, CA 90670
(562) 464-0099
(800) 227-4116