

OWNERS MANUAL

InPower UltraSwitch SSC Series DC Solid State Contactors

Models:

SSC 75-75
SSC 75-200

SSC 75-150
SSC 150-150



1. Introduction

InPower's UltraSwitch SSC Series is a family of dual solid state contactors with positive-voltage activated remote control, over-current shut down, and low battery voltage shut down. Under voltage protection will shut off the switches if the battery voltage decreases below 4.7 volts.

Over-current protection employs a sophisticated software-controlled scheme that incorporates a multi-level current/time profile, unlike fuses and mechanical circuit breakers that have one fixed curve determined by their thermal characteristics. The benefit of the multi-level approach is that over current shutdown protection can match more closely the characteristics of the various loads, which can have different turn-on surges and running amperages.

Connections for the high current DC cables utilize 3/8-16 stainless steel threaded studs. A unique standoff allows a rubber boot to be used for additional protection from the environment. The housing is completely sealed and utilizes a Delphi *Metri-Pak* 150 sealed control connector.

Remote control of the power switches requires a positive DC voltage to turn on the power switches. Under fault shutdown conditions, the remote input positive voltage must be removed and reapplied to reset the power switches. Internal temperature sensing will turn off the power switches if the internal temperature increases to 145° F.

2. System Diagram

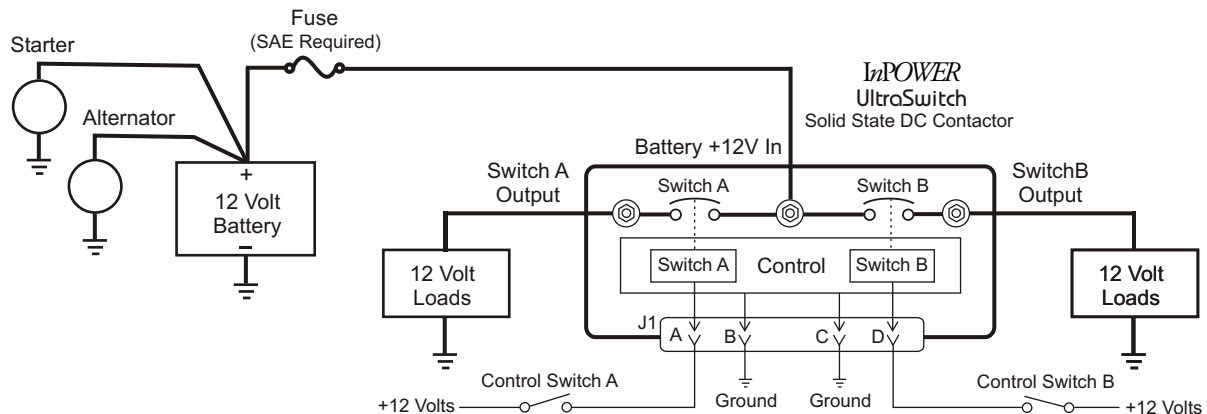

3. System Operation

Each of the two power switches (Switch A and Switch B) are controlled by their respective control inputs. When the control input is $> +7.5$ Vdc, the power switch will turn on. Removing the positive voltage will turn the power switch off. If the power switch has turned off due to a fault condition (e.g., over current shutdown), the control input must be removed for over 2 seconds, then reapplied to reset the power switch.

Three levels of current interrupt protection are provided to match the various possible fault conditions. The first, Level A Protection, is for “hard short” faults that produce extremely high current levels. For these cases the power switch will supply current up to its current limit rating for a period of up to 0.30 milliseconds. The second, Level B, offers protection for “soft shorts” such as high inrush loads (motors, lamps, etc.). This level of protection allows a high level of current (the surge current rating) to be supplied for a short period of time to satisfy the load’s surge current demands. The Level B Protection curve starts at the surge current peak and tapers off to the continuous current rating value after 500 milliseconds has passed (see Figure 1 Graph). The third level of protection, Level C, is the power switch’s continuous current rating. This begins after the Level B protection curve taper ends at 500 milliseconds. The current rating values for the three power switch sizes are shown in Table A.

Table A

Power Switch Current Ratings			
Power Switch	Continuous Rating	Surge Rating	Current Limit Rating
75	75 Amps	225 Amps	500 Amps
150	150 Amps	450 Amps	1000 Amps
200	200 Amps	675 Amps	1500 Amps

NOTE - The device’s total continuous current rating (Switch A + Switch B) at the *Battery +12V In* terminal is 250 amps maximum.

Figure 1

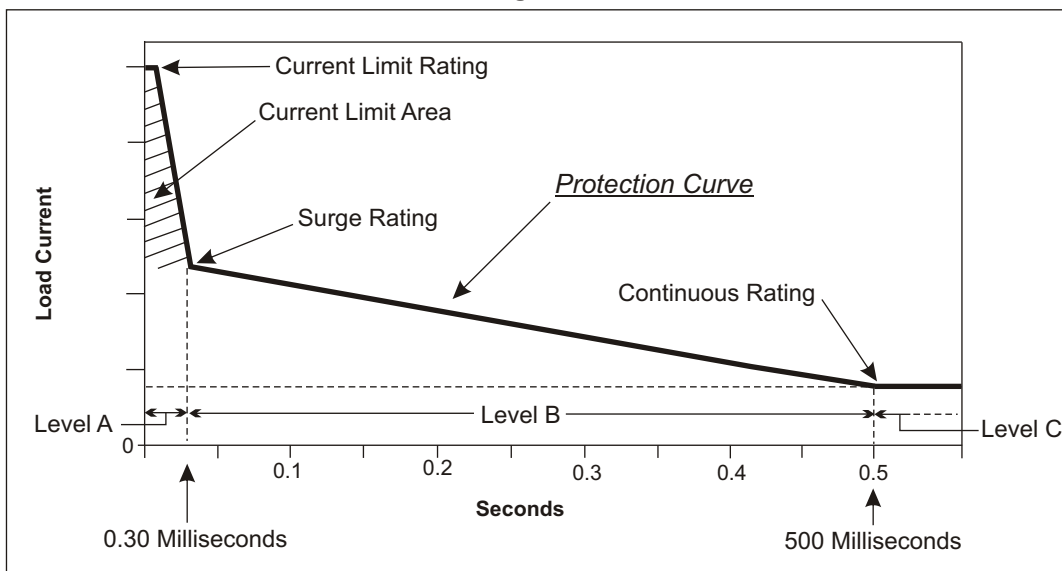

4. Specifications

Operating Voltage Range:
Current Rating:

+5.0 to +18 volts (14.2 volt nominal)

	Continuous Current Rating*		Surge Current Rating	
	Switch A	Switch B	Switch A	Switch B
Model SSC 75-75	75 amps	75 amps	225 amps	225 amps
Model SSC 75-150	75 amps	150 amps	225 amps	450 amps
Model SSC 75-200	75 amps	200 amps	225 amps	675 amps
Model SSC 150-150	150 amps	150 amps	450 amps	450 amps

* The device's total continuous current rating (Switch A + Switch B), at the Battery In terminal, is 250 amps maximum.

Low Voltage Shutoff:

Trip Voltage: 4.7 volts

Case Operating Temperature Range:

-40° F to +145° F

Turn On Delay (Control Signal to Output):

500 milliseconds

Turn Off Delay (Control Signal to Output):

500 milliseconds

Control Signal Reset Time:

Off for >2 seconds to reset fault shutdown

Control Connector (J1):

Type:

Delphi *Metri-Pak* Sealed 150 (4-terminal)

Terminals: Pin A

> +7.5 Vdc to close Switch A; Remove +Vdc to reset or open switch

Pin B

Ground (Battery Negative)

Pin C

Ground (Battery Negative)

Pin D

> +7.5 Vdc to close Switch B; Remove +Vdc to reset or open switch

Weight:

1.80 lbs

Dimensions:

4.00" x 6.50" x 1.89"

Connector Pin Layout:

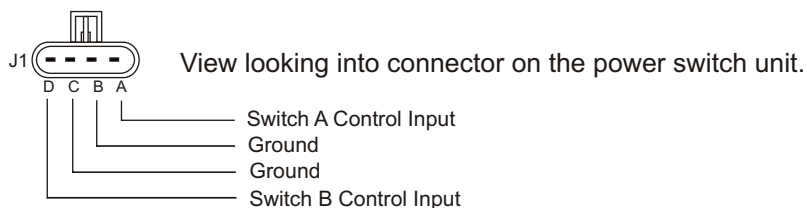

5. Mechanical Drawing

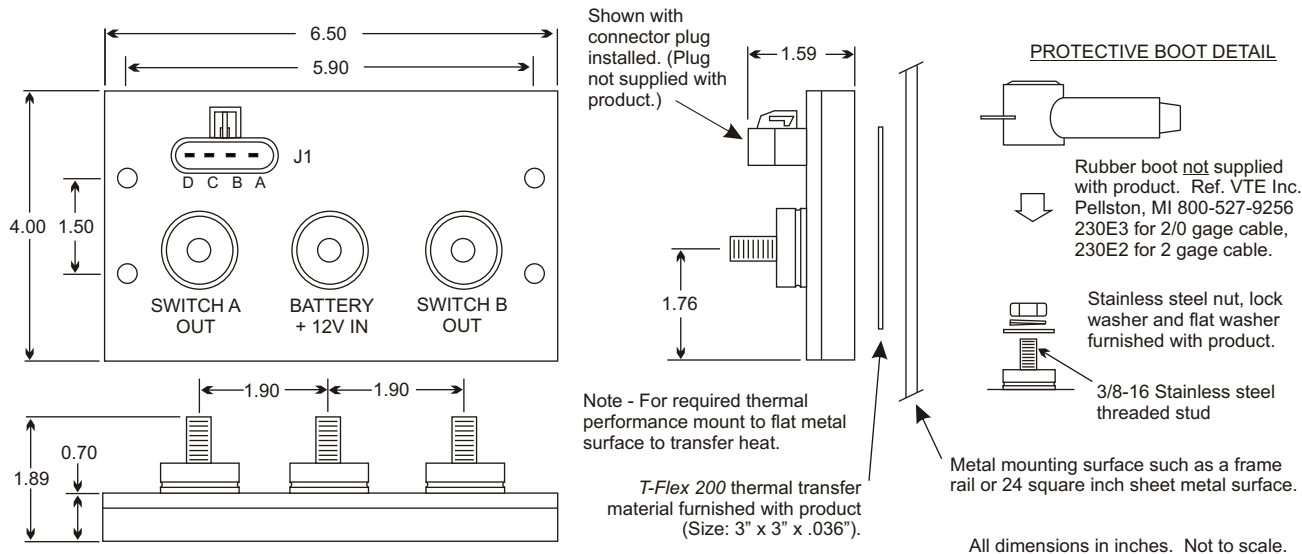

6. Installation Procedure

6.1 Introduction

This manual provides instructions for installing the InPower Series SSC UltraSwitch Electronic DC Contactors. It is important that you follow these instructions carefully and contact InPower if you need assistance or more information. You can reach InPower at:

InPower LLC
Customer Support
740-548-0965

This product requires the installer to be trained to install and work on vehicle electrical systems. We recommend that all wiring meet the SAE and applicable vehicle manufacturer's wiring specifications.

This product installation requires additional parts and materials that are not supplied with the product. Identify all required necessary parts before starting the installation and ensure that these items are the correct type and quality.

Inspect the product and all other components for damage before starting the installation. Do not perform the installation if any problems exist.

6.2 Safety Precautions

Read and understand the instructions in this manual and in any other applicable equipment manuals before starting the installation.

Make sure that the vehicle battery power is disconnected during installation of the power switch. Reconnect the battery when the system installation is complete.

Wear appropriate safety equipment, such as protective eyeglasses, face shield and clothing when installing equipment and handling the battery.

Be careful when working near a battery. Make sure that the area is well ventilated and that there are no flames near the battery. Never lay objects on the battery that can short the terminals together. If battery acid gets in your eyes, immediately seek first aid. If acid gets on your skin, immediately wash it off with soap and water.

6.3 Getting Started



WARNING

Do not weld on the vehicle with the SSC Solid State Contactor installed as damage to the product may result. If electric welding is necessary, disconnect the control connector and the DC cables attached to the Switch A Out and Switch B Out terminals. Damage due to electric welding while the SSC unit is installed will void InPower's warranty.

First determine the location for mounting the power switch. This can be near the vehicle battery to minimize the length of the cable between the battery +12 volt terminal and the power switch's *Battery +12 V IN* terminal. **The unit should not be located in the engine compartment or any location near the engine's heat.**

If the location is exposed to the environment we recommend that protective rubber boots be installed on the three power terminals. See *Section 7. Reference Information* for part numbers and purchasing source.

The control circuit will require a Delphi *Metri-Pak 150* 4-pin female sealed connector assembly. See *Section 7. Reference Information* for part numbers and purchasing source.

6.4 Mounting and Wiring Instructions



Make sure that the vehicle battery power is disconnected during installation of the power switch. Reconnect the battery when the system installation is complete.

Mounting the Power Switch

To ensure that the power switch's current rating specification is achieved, it is necessary to mount the unit to a flat metal surface. The mounting surface must have sufficient mass to absorb heat from the power switch. This can be a thick metal surface such as a chassis frame rail or a thinner sheet metal surface 24 inches square. To facilitate heat transfer a 3" x 3" square piece of T-Flex material is supplied with each power switch. Remove the clear plastic protective covering and insert the T-Flex heat transfer material between the power switch and the mounting surface. Secure the power switch to the mounting surface using four bolts.

Wiring the Power Cables

Wire the *Battery +12V IN* terminal on the power switch to the vehicle battery + post using a suitable size cable for the current handling requirement. We recommend installing a fuse or fuse link at the battery end of the wire to protect the wire to the power switch. Wire the *Switch A Out* and *Switch B Out* terminals to their respective 12 volt loads, using suitable size wire for the current handling requirements. Be sure that all wire crimp connections are high quality and secure.

Depending on the environment of the power switch location you may wish to use protective rubber boots over the three power terminals. Although the power switch is sealed, and its power terminals are stainless steel, the rubber boots are recommended for additional protection from the elements, and from accidental shorting. Note that these rubber boots are not supplied with the power switch. See *Section 7. Reference Information* for part numbers and purchasing source.

Wiring the Control Circuit

You will need a four-pin Delphi *Metri-Pak 150* sealed plug to terminate to the connector J1. See *Section 7. Reference Information* for part numbers and purchasing source.

Each of the two internal power switches (Switch A and Switch B) use a separate J1 connector pin to control the switch operation. These control inputs require a positive DC voltage (>7.5 Vdc) connection to turn the power switch on. Wire J1 pin A to a positive dc voltage source that will turn Switch A on (This could be a switch or relay contact wired to +12 volts). Wire J1 pin D to a positive dc voltage source that will turn Switch B on (This could be a switch or relay contact wired to +12 volts). Wire J1 pins B and C to a good ground (battery negative).

Metri-Pak Female Connector Assembly



7. Reference Information

A. Inpower SSC Series UltraSwitch Solid State Contactors Product Data Sheet: InPower document: PDS-43

B. Delphi *Metri-Pak* Connectors:
Power & Signal Group
Tel: 888-722-5273
www.powerandsignal.com

Part Description	Part Number
Female connector assy.	12162144
Female terminals	12084200
TPA (Terminal Position Assurance)	12047948
Cable seals*:	
2.85 - 2.03 mm diameter (Dk. Red)	12052924 (Reel) 12048086 (Loose)
2.15 - 1.60 mm diameter (White)	12089442 (Reel) 12089678 (Loose)
1.70 - 1.29 mm diameter (Blue)	12052925 (Reel) 12048087 (Loose)
1.009 - 0.995 mm diameter (Tan)	12124669 (Reel) 12084193 (Loose)
Cavity plug**	12059168
Crimping tool (20-14 Ga.)	12155975

* Select based on cable diameter (mm). Four required. Available loose or on a reel.

** Required if any cavity is not occupied with a terminal/cable seal.

C. Protective Rubber Boots:
VTE Inc.
Pellston, MI
800-527-9256

Rubber Boot:
VTE Part No: 230E2V02
Color: Red

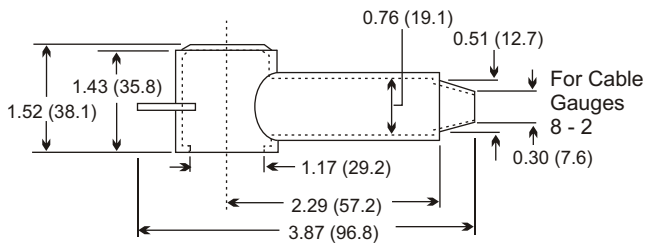

Rubber Boot:
VTE Part No: 230E3V02
Color: Red

