

OWNERS MANUAL

InPower Model EHS-C1 Dual Electronic Diesel Engine Heater Switch

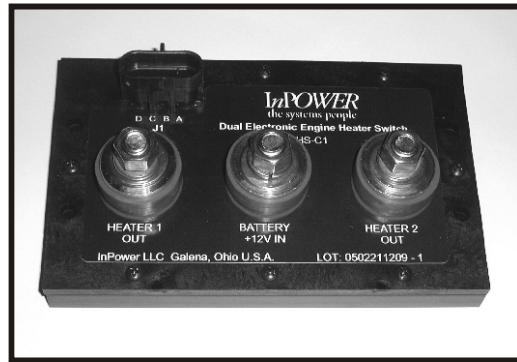

1. Introduction

The InPower Model EHS-C1 is a dual electronic dc power switch for controlling the two intake air heater coils on Cummins diesel engines, thereby providing a highly reliable alternative to the typical mechanical relays. The dual power switch operates from positive voltage control (+12 Volts) and can be controlled directly from the Cummins engine control module (ECM).

The EHS-C1 dual power switch provides over current automatic shutdown protection. The two electronic power switches are rated individually at 150 amps continuous. The housing is completely sealed and utilizes a Delphi *Metri-Pak 150* sealed control connector.

Connections for the high current dc cables utilize 3/8-16 stainless steel threaded studs. A unique standoff allows a rubber boot to be used for additional protection from the environment. This rubber boot comes standard with the EHS-C1.

Remote control of the power switches require a positive voltage of >7.5 Vdc to turn the power switches on. Under fault shutdown conditions the remote input control voltage must be removed and reapplied to reset the power switches. Internal temperature sensing will turn off the power switches if the internal temperature increases to 145°F.

2. System Diagram

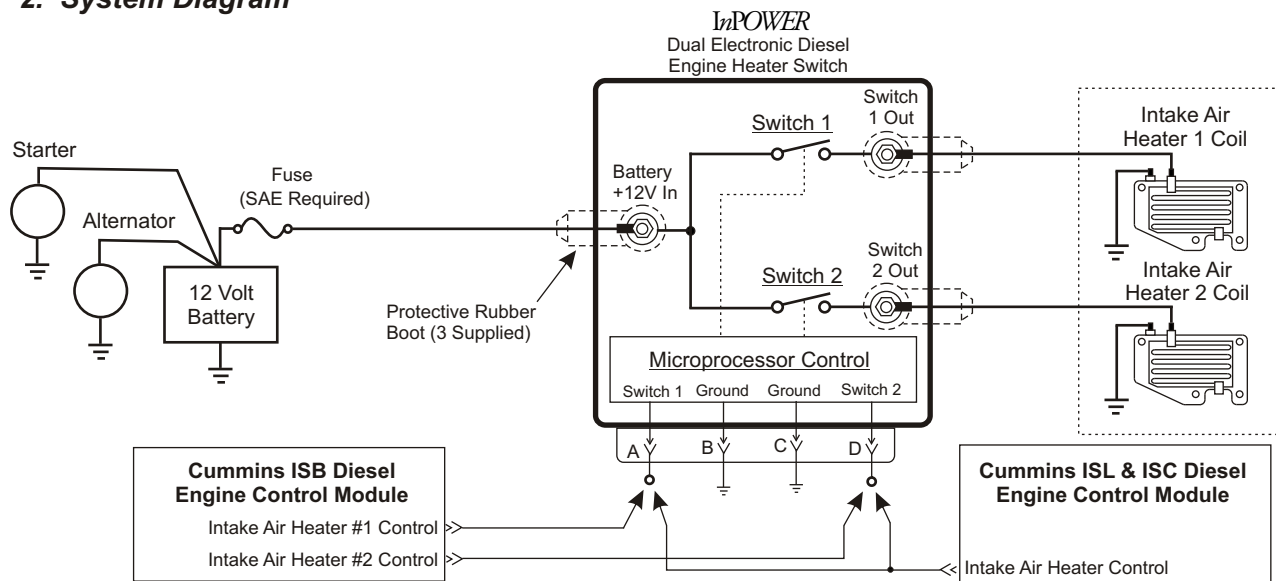

3. System Operation

Each of the two power switches (Switch 1 and Switch 2) are controlled by their respective control inputs. When the control input is $> +7.5$ Vdc, the power switch will turn on. Removing the positive voltage will turn the power switch off. If the power switch has turned off due to a fault condition (e.g., over current shutdown), the control input must be removed for over 2 seconds, then reapplied to reset the power switch.

Three levels of current interrupt protection are provided to match the various possible fault conditions. The first, Level A Protection, is for "hard short" faults that produce extremely high current levels. For these cases the power switch will supply current up to its current limit rating of 1,000 amps for a period of up to 0.30 milliseconds. The second, Level B, offers protection for "soft shorts" such as high inrush loads. This level of protection allows a high level of current (the surge current rating) to be supplied for a short period of time to satisfy the load's surge current demands. The Level B Protection curve starts at the surge current peak (450 amps) and tapers off to the continuous current rating value of 150 amps after 500 milliseconds has passed (see Figure 1 Graph). The third level of protection, Level C, is the power switch's continuous current rating of 150 amps. This begins after the Level B protection curve taper ends at 500 milliseconds.

Figure 1

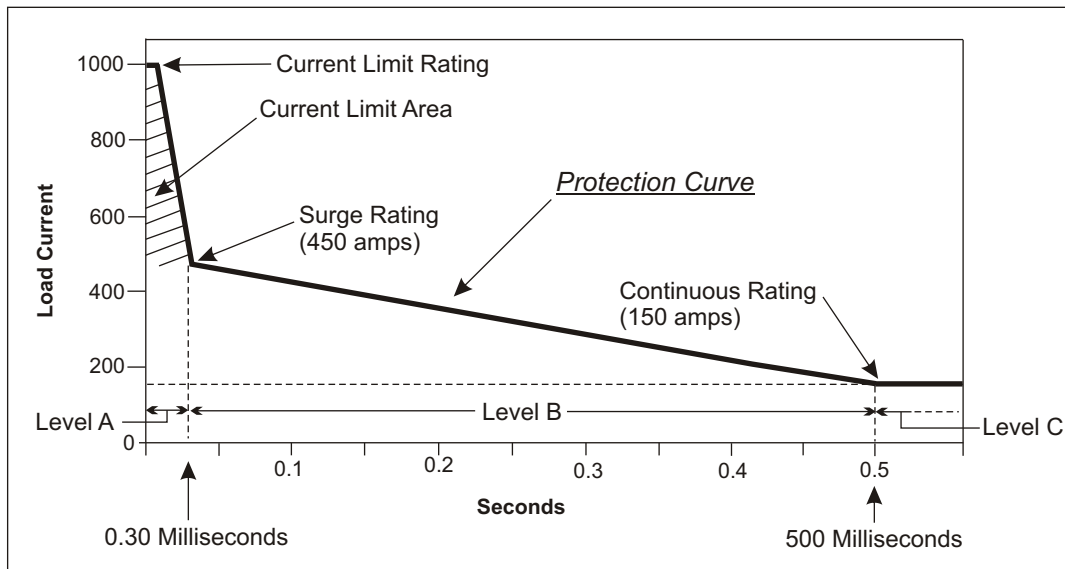

4. Specifications

| | |
|--|---|
| Operating Voltage Range: | +5.0 to +16.5 volts |
| Current Rating: | |
| Switch A: | 150 amps |
| Switch B: | 150 amps |
| Low Voltage Shutoff: | |
| Trip Voltage: | 4.7 volts |
| Case Operating Temperature Range: | -40° F to +145° F |
| Turn On Delay (Control Signal to Output): | 500 milliseconds |
| Turn Off Delay (Control Signal to Output): | 500 milliseconds |
| Control Signal Reset Time: | Off for >2 seconds to reset fault shutdown |
| Control Connector (J1): | |
| Type: | Delphi <i>Metri-Pak</i> Sealed 150 (4-terminal) |
| Terminals: | Pin A > +7.5 Vdc to close Switch A; Remove +Vdc to reset or open switch |
| Pin B | Ground (Battery Negative) |
| Pin C | Ground (Battery Negative) |
| Pin D | > +7.5 Vdc to close Switch B; Remove +Vdc to reset or open switch |
| Weight: | 1.80 lbs |
| Dimensions: | 4.00" x 6.50" x 1.89" |
| Rubber Boot: | VTE Part No. 230E2V02 Three (3 supplied) |

Rubber Boot Detail

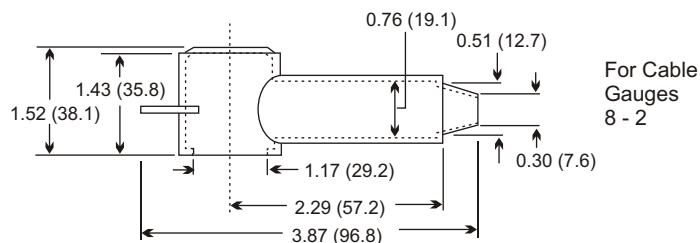

Connector Pin Layout:

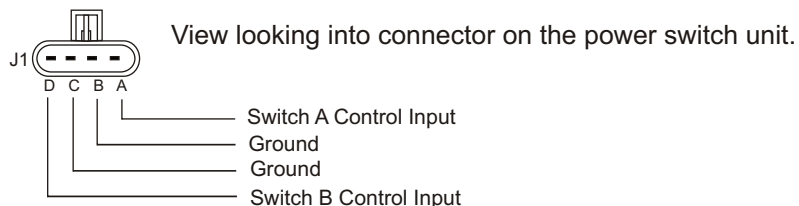

5. Mechanical Drawing

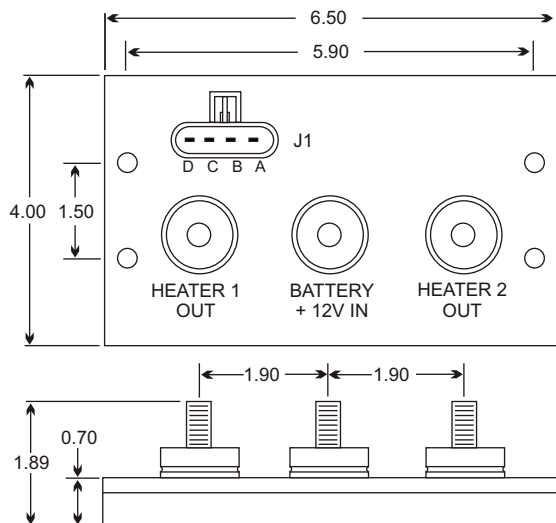

Shown with connector plug installed. (Plug not supplied with product.)

Note - For required thermal performance mount to flat metal surface to transfer heat.

T-Flex 200 thermal transfer material furnished with product (Size: 3" x 3" x .036").

PROTECTIVE BOOT DETAIL

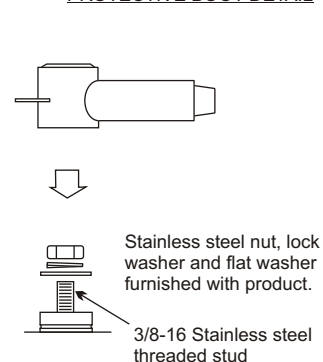

Metal mounting surface such as a frame rail or 24 square inch sheet metal surface.

All dimensions in inches. Not to scale.

6. Installation Procedure

6.1 Introduction

This manual provides instructions for installing the InPower Series SSC UltraSwitch Electronic DC Contactors. It is important that you follow these instruction carefully and contact InPower if you need assistance or more information. You can reach InPower at:

InPower LLC
Customer Support
740-548-0965

This product requires the installer to be trained to install and work on vehicle electrical systems. We recommend that all wiring meet the SAE and applicable vehicle manufacturer's wiring specifications.

This product installation requires additional parts and materials that are not supplied with the product. Identify all required necessary parts before starting the installation and ensure that these items are the correct type and quality.

Inspect the product and all other components for damage before starting the installation. Do not perform the installation if any problems exist.

6.2 Safety Precautions

Read and understand the instructions in this manual and in any other applicable equipment manuals before starting the installation.

Make sure that the vehicle battery power is disconnected during installation of the power switch. Reconnect the battery when the system installation is complete.

Wear appropriate safety equipment, such as protective eyeglasses, face shield and clothing when installing equipment and handling the battery.

Be careful when working near a battery. Make sure that the area is well ventilated and that there are no flames near the battery. Never lay objects on the battery that can short the terminals together. If battery acid gets in your eyes, immediately seek first aid. If acid gets on your skin, immediately wash it off with soap and water.

6.3 Getting Started



WARNING

Do not weld on the vehicle with the EHS-C1 Solid State Contactor installed as damage to the product may result. If electric welding is necessary, disconnect the control connector and the DC cables attached to the Heater 1 Out and Heater 2 Out terminals. Damage due to electric welding while the SSC unit is installed will void InPower's warranty.

First determine the location for mounting the power switch. This can be near the vehicle battery to minimize the length of the cable between the battery +12 volt terminal and the power switch's *Battery +12 V IN* terminal. **The unit should not be located in the engine compartment or any location near the engine's heat.**

If the location is exposed to the environment we recommend that protective rubber boots be installed on the three power terminals. See *Section 7. Reference Information* for part numbers and purchasing source.

The control circuit will require a Delphi *Metri-Pak 150* 4-pin female sealed connector assembly. See *Section 7. Reference Information* for part numbers and purchasing source.

6.4 Mounting and Wiring Instructions



Make sure that the vehicle battery power is disconnected during installation of the power switch. Reconnect the battery when the system installation is complete.

Mounting the Power Switch

To ensure that the power switch's current rating specification is achieved, it is necessary to mount the unit to a flat metal surface. The mounting surface must have sufficient mass to absorb heat from the power switch. This can be a thick metal surface such as a chassis frame rail or a thinner sheet metal surface 24 inches square. To facilitate heat transfer a 3" x 3" square piece of T-Flex material is supplied with each power switch. Remove the clear plastic protective covering and insert the T-Flex heat transfer material between the power switch and the mounting surface. Secure the power switch to the mounting surface using four bolts.

Wiring the Power Cables

Wire the *Battery +12V IN* terminal on the power switch to the vehicle battery + post using a suitable size cable for the current handling requirement. We recommend installing a fuse or fuse link at the battery end of the wire to protect the wire to the power switch. Wire the *Heater 1 Out* and *Heater 2 Out* terminals to their respective 12 volt heater coils, using suitable size wire for the current handling requirements. Be sure that all wire crimp connections are high quality and secure.

Depending on the environment of the power switch location you may wish to use protective rubber boots over the three power terminals. Although the power switch is sealed, and its power terminals are stainless steel, the rubber boots are recommended for additional protection from the elements, and from accidental shorting. Note that these rubber boots are not supplied with the power switch. See *Section 7. Reference Information* for part numbers and purchasing source.

Wiring the Control Circuit

You will need a four-pin Delphi *Metri-Pak 150* sealed plug to terminate to the connector J1. See *Section 7. Reference Information* for part numbers and purchasing source.

Each of the two internal power switches (Switch 1 and Switch 2) use a separate J1 connector pin to control the switch operation. These control inputs require a positive DC voltage (>7.5 Vdc) to turn the power switch on. Wire J1 pin A to the Cummins Engine Control Module (ECM) output for Heater #1 Control and J1 pin D to the ECM's output for Heater #2 Control. If the ECM has only one output for both heaters, wire the single output to both pin A and pin D.

Metri-Pak Female Connector Assembly

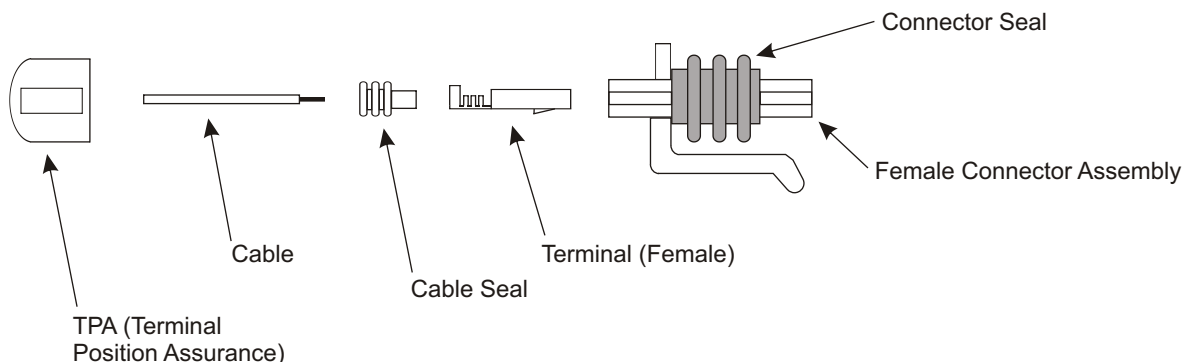

7. Reference Information

- A. Inpower SSC Series UltraSwitch Solid State Contactors Product Data Sheet: InPower document: PDS-43
- B. Delphi *Metri-Pak* Connectors:
Power & Signal Group
Tel: 888-722-5273
www.powerandsignal.com

| <u>Part Description</u> | <u>Part Number</u> |
|-----------------------------------|----------------------------------|
| Female connector assy. | 12162144 |
| Female terminals | 12084200 |
| TPA (Terminal Position Assurance) | 12047948 |
| Cable seals*: | |
| 2.85 - 2.03 mm diameter (Dk. Red) | 12052924 (Reel) 12048086 (Loose) |
| 2.15 - 1.60 mm diameter (White) | 12089442 (Reel) 12089678 (Loose) |
| 1.70 - 1.29 mm diameter (Blue) | 12052925 (Reel) 12048087 (Loose) |
| 1.009 - 0.995 mm diameter (Tan) | 12124669 (Reel) 12084193 (Loose) |
| Cavity plug** | 12059168 |
| Crimping tool (20-14 Ga.) | 12155975 |

* Select based on cable diameter (mm). Four required. Available loose or on a reel.

** Required if any cavity is not occupied with a terminal/cable seal.

