

# InPOWER

the systems people

## OWNERS MANUAL

### Solid State Contactors Models: SSC10-100, SSC10-150 & SSC10-200



## Introduction

The InPower SSC10 Series is a family of high current solid state contactors that utilize a highly efficient electronic power switch to connect the vehicle's battery to 12 volt loads. These devices require a positive voltage to actuate the power switch, and provide automatic shut down protection for over-current, over temperature, loss of ground, low input control voltage and low battery voltage. Under fault shut down conditions, the input control voltage must be removed, then reapplied to reset the unit.

The current ratings will depend upon the maximum ambient temperature and the effectiveness of the mounting surface's heat sink capabilities. If the internal temperature reaches +85° C due to a combination of high ambient temperature and high current it will shut down to protect itself.

Connections for the high current dc cables utilize 3/8 - 16 stainless steel threaded studs. The terminal design allows the use of an optional rubber terminal boot cover for added protection from the environment, as well as from accidental shorting.

## System Diagram

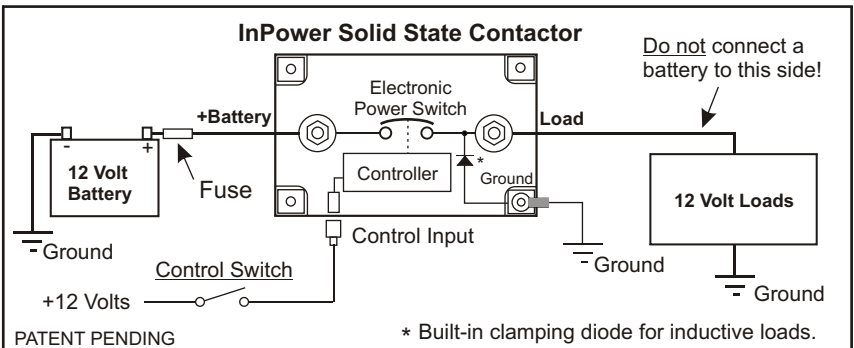

## System Operation

The solid state contactor is controlled by a positive voltage on its control input terminal. The must operate voltage is +9.5 Vdc. The must release voltage is +8.0 Vdc. Note that the input voltage must drop to zero volts, then increase to +9.5 Vdc in order to turn on again.

Certain fault conditions will cause the power switch to turn off and remain latched off until the control input voltage is removed, then re-applied. These fault conditions include:

1. An over current for greater than 400 milliseconds
2. A case temperature of +85° C
3. Loss of ground
4. Low control input voltage

## Specifications

Operating Voltage Range: +9.5 to +18.5 volts (14.2 volt nominal)

Current Rating:

	<u>SSC10-100</u>	<u>SSC10-150</u>	<u>SSC10-200</u>
Max. current at 110° F (43°C)*			
Type A mounting**	100 Amps	150 Amps	200 Amps
Type B mounting**	75 Amps	100 Amps	125 Amps

On-resistance at maximum current and temperature: 2.2 milliohms 1.1 milliohms 0.75 milliohms

\* Mounting surface temperature. Note - The maximum current rating will be derated above 110° F (43°C).

\*\* Mounting Surface Types:

Type A - Mounting surface such as a steel vehicle frame rail or aluminum plate 0.125" x 16" x 16" or larger.

Type B - Mounting surface such as wood, plastic or free air.

Case Maximum Temperature: +85° C

Turn-On Delay: 2 milliseconds

Turn-Off Delay: 2 milliseconds

Control Connector Type: 0.250 inch male Faston blade terminal

Control Input Voltage: >+9.5 Vdc to activate; <+8.0 Vdc to deactivate

Control Input Current: Zero current draw when input is deactivated.

When input is activated, current draw is 10 milliamps @13.5 Vdc input voltage.

Weight: 0.30 lbs (0.136 kg)

Dimensions: 2.7 x 4.2 x 0.925 inches (68.6 x 106.7 x 23.5 mm)

Power Terminals: Two (2) 3/8 - 16 threaded stainless steel studs, with nuts and lock washers. Rubber terminal boot covers are optional.

Power Terminal Torque: 10 Foot-Pounds Minimum  
15 Foot-Pounds Maximum

## Installation Procedure

### **WARNING!**

**Do not weld on the vehicle with the Solid State Contactor installed as damage to the product may result. If electric welding is necessary, disconnect the control terminal and the cables attached to the LOAD and BATTERY + terminals. Damage due to electric welding while the unit is installed will void InPower's warranty.**

This product requires the installer to be trained to install and work on vehicle electrical systems. We recommend that all wiring meet the SAE and applicable vehicle manufacturer's wiring specifications. Inspect the product and all other components for damage before starting the installation. Do not perform the installation if any problems exist.

Make sure that the vehicle battery power is disconnected during installation of the contactor. Reconnect the battery when the system installation is complete. Wear appropriate safety equipment, such as protective eyeglasses, face shield and clothing when installing equipment and handling the battery. Be careful when working near a battery. Make sure that the area is well ventilated and that there are no flames near the battery. Never lay objects on the battery that can short the terminals together. If battery acid gets in your eyes, immediately seek first aid. If acid gets on your skin, immediately wash it off with soap and water.

### Mounting Location

First determine where the contactor will be mounted. We recommend mounting it to a metal surface that can absorb heat produced by the unit. Also take into consideration the maximum current needed and the maximum ambient temperature (See Specifications Section). **The unit should not be located in the engine compartment or any location near the engine's heat.** For maximum thermal efficiency the mounting surface should be a thick metal surface such as a chassis frame rail or an aluminum plate 1/8 x 16 x 16 inch or larger. To facilitate heat transfer a square piece of thermal transfer material is supplied with each power switch. Remove the clear plastic protective covering and insert the heat transfer material between the power switch and the mounting surface. Secure the power switch to the mounting surface using four screws. If the mounting surface is a good quality ground (low resistance to the battery negative terminal) the mounting screws will provide a good ground connection. If the mounting surface is not a good ground, or you are not sure, you must install a ground wire with a ring terminal under one of the mounting screws.

### Connect the Power Cables

**First, make sure that the battery is disconnected.** Prepare the cable to the battery using a suitable size cable for the current required and install a crimped lug terminal on the end. Be sure that you have installed a protection device (fuse, fuse link or circuit breaker) at the battery end of the cable. If required, install a rubber terminal boot over the cable and lug, then install the cable as shown in the diagram on page 4. Torque the nut to the value shown in the diagram. Slide the boot over the lug and into the detent groove on the power terminal. Prepare the cable to the loads and install the cable as you did with the battery cable.

### Control Circuit

The control wire must provide a positive voltage of at least +9.5 volts to actuate the power switch. This could be, for example, a toggle switch wired to the +12 volt battery. Crimp a female 0.250 inch Faston terminal on the control wire and connect it to the control input (male) terminal.

## Installation Diagram

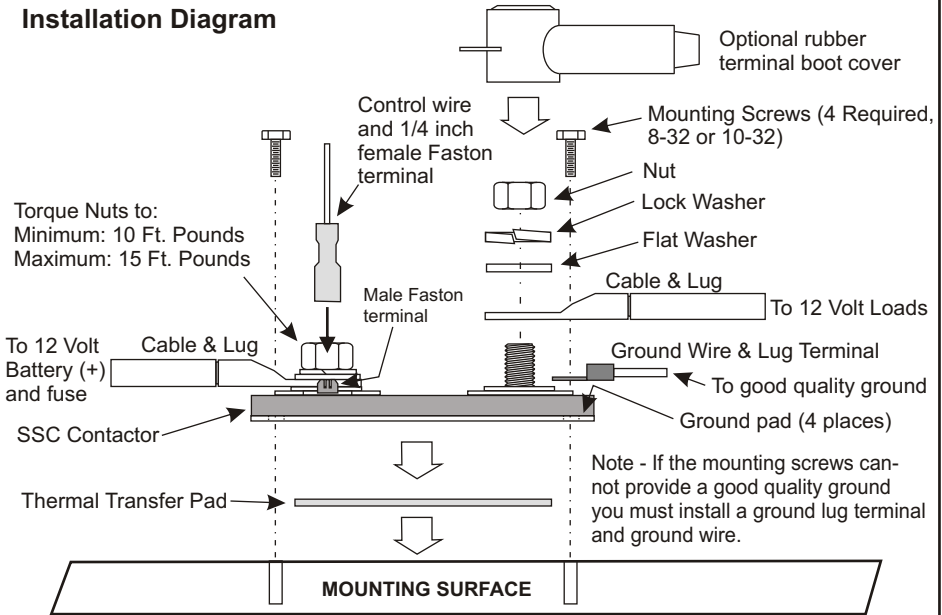

### IMPORTANT NOTE -

The mounting surface provides a means to remove heat that is generated by the SSC contactor. If this surface is a poor conductor of heat the SSC contactor will have a lower current rating than if the surface is a good conductor of heat and has a sufficiently large area.

## Mechanical Diagram

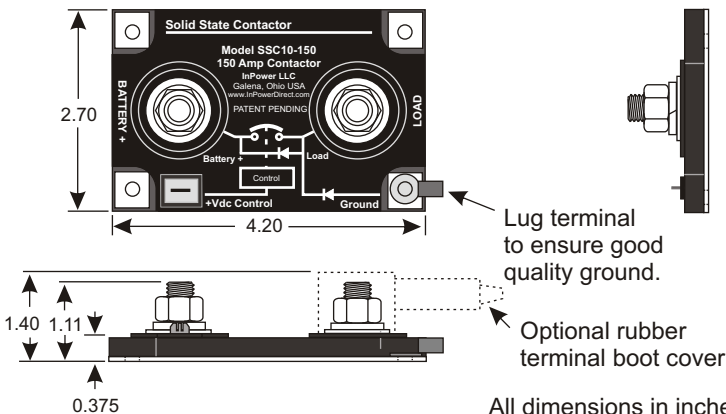

### InPOWER LLC

3555 Africa Road

Galena, Ohio 43021

Tel 740-548-0965 Fax 740-548-2302

www.InPowerDirect.com