

Installer Notes:

InPOWER
the systems people
InPOWER LLC
3555 Africa Road
Galena, Ohio 43021 U.S.A.
(740)548-0965
www.InPowerDirect.com

Owners Manual
Model ETM51 Electronic Throttle
Document: OM-54 Version D
Date: December 16, 2008

© Copyright 2008 InPower LLC

InPOWER

InPOWER
the systems people

OWNERS MANUAL
Model ETM51
Electronic Throttle Module
2005 - 2009 Ford Gas & Diesel Engines

A. Introduction

The InPower Model ETM51 electronic throttle module is designed for installation in 2005 - 2009 Ford trucks and vans that are equipped with the Ford *Stationary Elevated Idle Control* (SEIC) and have one the following engines:

- 6.4 Liter *Power Stroke* Diesel
- 6.0 Liter *Power Stroke* Diesel
- 6.8 Liter *Triton* Gas
- 5.4 Liter *Triton* Gas

Four modes of fast idle control are provided, including three fast idle preset speeds (user adjustable), and a variable speed input (remote variable resistor). The ETM51 electronic throttle installation requires customer supplied control wiring to select the required mode of operation and to connect to the Ford SEIC (Stationary Elevated Idle Control) wiring (Ford provides blunt-cut wires). This wiring connects to the ETM51 module via 0.25 inch Faston (blade) terminals. The ETM51 system is supplied with a three-foot shielded data cable. This cable contains a 16-pin connector at one end and two 0.25 inch Faston terminals at the other end. The Faston terminals will connect at the ETM51 module and the 16-pin connector plug will attach to the vehicle's OBDII (On Board Diagnostic) data link connector (DLC). The DLC is usually located at the lower part of the dash on the driver's side.

B. Operation

When the vehicle is parked and **Chassis Ready Conditions** are satisfied the engine speed may be controlled by one of the four available modes (three preset speeds or the variable rpm). The preset speed may be adjusted by three calibration potentiometers on the top of the ETM51 module.

Chassis Ready Conditions are:

1. Parking brake is set
2. Gear shift in "Park" (automatic transmission only)
3. Foot is off service brake
4. Foot is off the accelerator pedal
5. Vehicle is stationary (no speed)
6. Engine is started and idling below 900 rpm
7. Coolant temperature >140° F (Gas engine only)

Important Notes:

1. **Do not connect any other 12 volt source to the ETM51's PTO terminal!**
2. **If the engine is in the fast idle mode and one of the *Chassis Ready Conditions* inputs changes state, the engine will return to normal (low) idle speed. If the input then returns to satisfy the *Chassis Ready Conditions* while the fast idle mode is still selected, the diesel engine will automatically return to fast idle after about three seconds. However, the gas engine will not automatically return to the fast idle speed. To reset the Ford SEIC so that it will return to the fast idle, you must turn off the Fast Idle On/Off switch, then turn it back on.**

InPOWER

Modes Of Operation:

1. Three Preset RPM High Idle Modes:

Function: Increase idle to a preset rpm value
 Terminals: RPM1, RPM2, RPM3
 Activation: Apply +12 V to terminal
 Range of Calibration: 900 to 2250 rpm (gas engines)
 1200 to 2300 rpm (diesel engine)
 Type of Adjustment: Three potentiometers accessible from the top of the module

2. Variable RPM Mode:

Function: Varies rpm as a function of voltage on VRPM input terminal
 Terminal: VRPM
 Adjustment: 10K Ohm potentiometer between the VRPM terminal and ground
 Enable: Turn potentiometer down to zero resistance, then slowly increase until desired rpm is reached
 Disengage: Turn potentiometer down to zero and rpm will drop to standard idle speed
 RPM Range: 900 to 2250 rpm (gas engines)
 1200 to 2300 rpm (diesel engine)

3. Mode Priorities:

A mode priority selection scheme is provided that will eliminate conflicts if more than one mode is selected at a time. In the case of one or more modes being selected, the following priorities will be established:

RPM1 Highest - Will override RPM2, RPM3, VRPM
 RPM2 Second - Will override RPM3, VRPM
 RPM3 Third - Will override VRPM
 Variable RPM Lowest - Will only activate when other modes are off

Status Indicators

A 10 segment LED provides status and problem detection information. Refer to the following table for coding of these functions.

LED	Status	Indication
BUSS	On Solid	Module ON and functioning
BUSS	Flashing	Module ON, but a problem with CAN bus communications
GEAR	On Solid	Transmission in PARK position or Clutch Pedal released
GEAR	Flashing	Transmission <u>not</u> in PARK position or Clutch Pedal activated
PK BRK	On Solid	Park Brake set
PK BRK	Flashing	Park Brake <u>not</u> set
SR BRK	On Solid	Service Brake at rest (not activated)
SR BRK	Flashing	Service Brake activated
VSPEED	On Solid	Vehicle stationary
VSPEED	Flashing	Vehicle moving



DIESEL ENGINE CHASSIS WIRING DIAGRAM

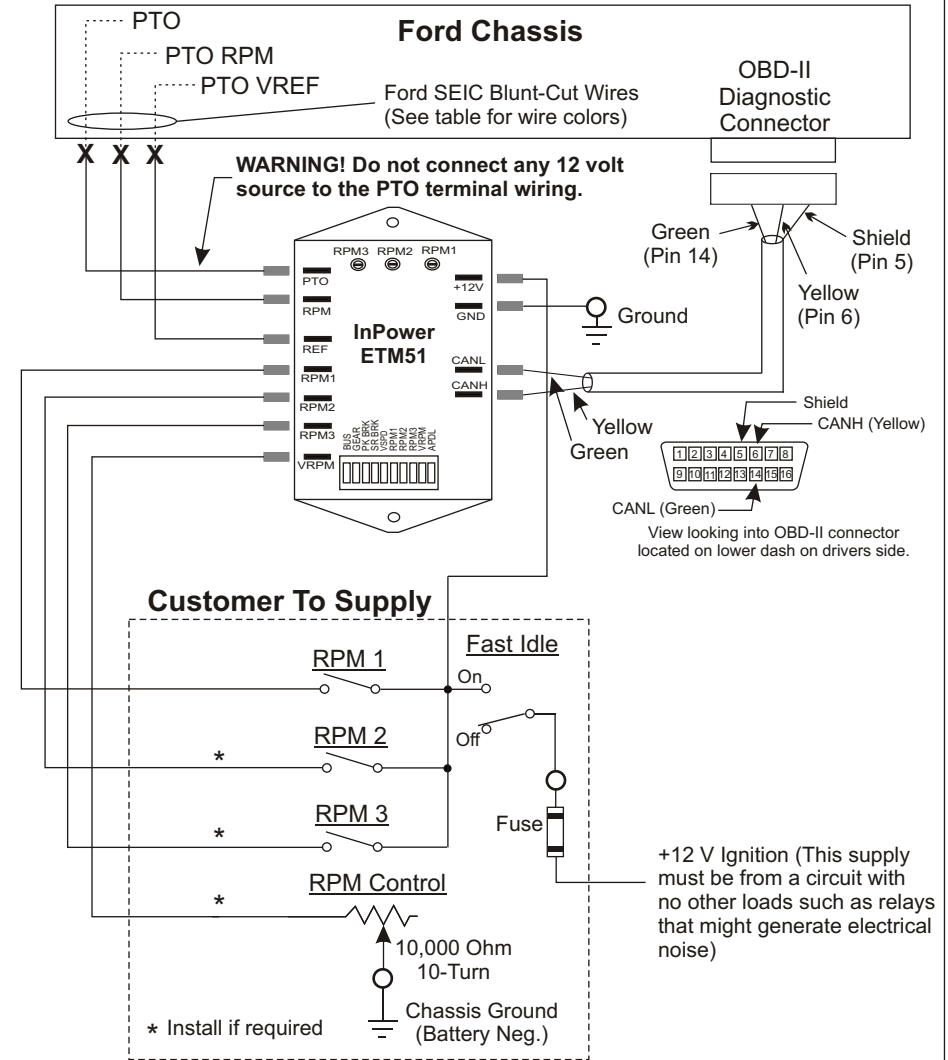

FORD SEIC WIRE COLOR CHART

Function	F-Series Diesel		E-Series Diesel	
	2005 - 2007 6.0 L	2008 - 2009 6.4 L	2005 - 2008 6.0 L	2009 6.0 L
PTO	Orange	Yellow/Green	Purple/Lt. Blue	Yellow/Green
PTO RPM	Orange/Yellow	Green	Orange/Yellow	Green
PTO VREF	Orange/Red	White/Brown	Orange/Red	White/Brown



GAS ENGINE CHASSIS WIRING DIAGRAM

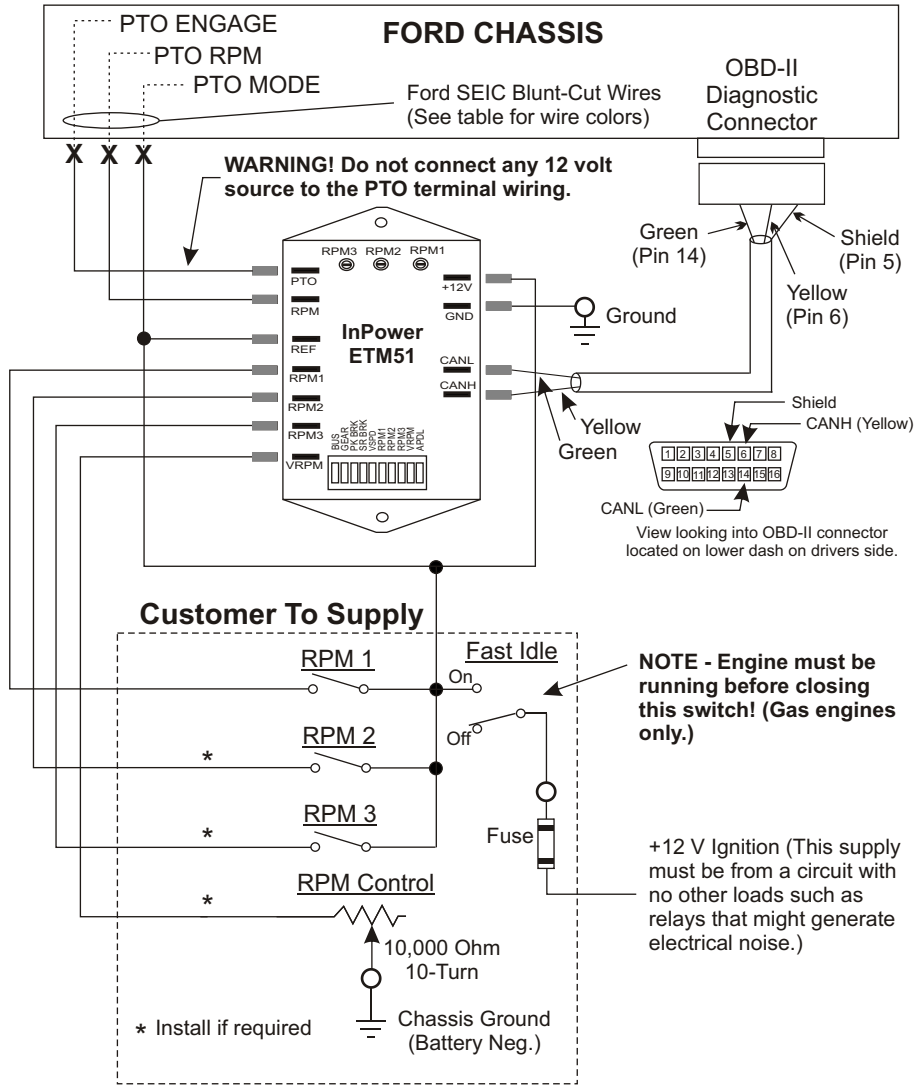

FORD SEIC WIRE COLOR CHART

Function	F-Series Gas			E-Series Gas	
	2005 - 2007 5.4 L	2005 - 2007 6.8 L	2008-2009 5.4 L & 6.8L	2005 - 2008 5.4 L & 6.8L	2009 5.4 L & 6.8 L
PTO MODE	Orange	Orange	Yellow/Green	Orange	Yellow/Green
PTO RPM	Orange/Yellow	Orange/Yellow	Green	Orange/Yellow	Green
PTO ENGAGE	Orange/White	Orange/White	Blue/Green	Orange/White	Blue/Green



Status Indicators (Continued)

RPM1	On Solid	RPM1 mode selected, engine at fast idle
RPM1	Flashing	RPM1 mode selected, engine <u>not</u> at fast idle (PCM not responding*)
RPM2	On Solid	RPM2 mode selected, engine at fast idle
RPM2	Flashing	RPM2 mode selected, engine <u>not</u> at fast idle (PCM not responding*)
RPM3	On Solid	RPM3 mode selected, engine at fast idle
RPM3	Flashing	RPM3 mode selected, engine <u>not</u> at fast idle (PCM not responding*)
VRPM	Off	VRPM terminal at zero resistance value (engine at idle) or open circuit
VRPM	On Solid	VRPM terminal increases above threshold level and engine speed increases accordingly.
VRPM	Flashing	VRPM terminal increases above threshold level but engine does not respond with elevated speed.
APDL	On Solid	Accelerator pedal at rest position
APDL	Flashing	Accelerator pedal actuated (not at rest position)

* The Ford powertrain control module (PCM) is not responding to the fast idle speed request. This could be caused by a chassis sensor interlock (See *Chassis Ready Conditions* on page 1 for required conditions to satisfy interlocks), or some other PCM system problem. This could also be caused by the failure to power the ETM51's +12 volt input until after the engine is started (gas engines only) and engine temperature is over 140° F. See note on page 6.

C. Installation

1. Getting Started

The recommended location for the ETM51 system is under the dash due to the proximity of the wiring connections and cable length. **The unit should not be located in the engine compartment, or any location that is not protected.** You will need a crimping tool for the 0.25 inch Faston (blade) terminals, and a wire stripping tool. Be sure to follow the crimping tool instructions for the proper wire size and terminals. **Do not lengthen the DLC Cable. Disconnect the battery before making any electrical connections.**

2. Mount the ETM51 Module

Mount the ETM51 module under the dash using the two mounting holes. Ensure that you have sufficient distance to install the 36 inch long DLC cable.

3. Install the DLC Cable

Connect the two Faston terminals on the DLC cable to the ETM51 module terminals (Yellow wire to CANH terminal and Green wire to CANL terminal). Route the cable to the OBDII Data Link Connector and plug it in. The OBDII connector is usually located on the lower part of the dash on the driver's side. Using a cable tie, secure the plug to the OBDII connector so that it will not vibrate out. We recommend that you route the DLC cable back across the bottom of the plug/connector, and loop the cable tie around the plug, socket and cable, thereby keeping the cable out of the way. Also ensure that the entire cable is routed and secured to keep it out of the way.



C. Installation (Cont'd):

4. Wire the Mode Selection and SEIC Controls

This section describes the wiring necessary to connect the ETM51 electronic throttle to the Ford SEIC blunt-cut wires and to the Mode Selection controls ("Customer to Supply"). As the wiring is different for gas and diesel engine applications, refer the appropriate wiring diagrams on page 6 and 7. You will also need to obtain a good quality chassis ground (battery negative) and a +12 volt supply that is fed from the Ignition Switch. **Note that on gas engine installations, Ford requires this +12 volt supply to be "clean." That is, it should not have any other loads such as relays on the same circuit that could generate electrical noise.**

4A. Idle Speed Mode Controls

First, determine the combination of fast idle speed modes that you will need (variable rpm control and/or up to three fixed preset speeds). You will need a 10,000 Ohm potentiometer for the variable rpm control, and a switch (or relay contact) for the fixed speed presets (RPM1, RPM2 & RPM3). You will also need a Fast Idle On/Off switch. Wire these devices as shown in the Wiring Diagram - Gas Engines (Page 6) and Wiring Diagram - Diesel Engines (Page 7). You will need to obtain a good quality chassis ground (battery negative) and a +12 volt fused supply fed from the Ignition Switch. Refer to the Ford Body Builders Layout Book for location of these circuits.

Note on Variable RPM Control - If you are using the Variable RPM mode you will need to supply a 10,000 ohm variable resistor (potentiometer) between the VRPM terminal on the ETM module and ground. We recommend a ten-turn potentiometer such as is available from Williams Controls (www.wmco.com), Teleflex (www.teleflex.com) or Felsted (www.felsted.com).

4B. Ford SEIC Wiring

Install wires between the ETM51 module and the Ford SEIC as shown in the wiring diagrams on page 5 and 6. The Ford SEIC wires are blunt-cut, color coded wires located above the parking brake pedal on the F-Series trucks. On E-Series vans they are located in the engine compartment on the top, driver's side of the firewall. Refer to Ford SEIC documentation for more details. **Note that the wiring is different for the gas and diesel engines. Also, the gas engine application requires a "clean" +12 volt power source. This must be a +12 volt circuit switched by the ignition switch that is isolated from other circuits. That is, no other loads such as relays can be on the same circuit.**

WARNING!

Do not connect any 12 volt source to the ETM51's PTO terminal wiring.

D. Setup and Calibration

The only calibration required is to select each of the three preset rpm modes (RPM1, RPM2 & RPM3) and adjust the three respective calibration potentiometers on the top of the ETM51 module to the desired speed (900 through 2,250 rpm on gas engines and 1200 to 2300 rpm on the diesel engine). Adjustments can be made with a 1/16" (1.6 mm) or smaller screw driver. Each potentiometer is a ten turn module, with an increase or decrease of about 300 rpms per complete turn.

E. Specifications

Electrical

Input Voltage (+12V Terminal): 8 to 16 volts
Input Current (+12V Terminal): 30 mA

Mechanical

Weight: 0.17 lbs
Connections: Faston 0.25 inch terminals
Case Material: Cyolac thermoplastic (UL 94VO)
Encapsulation Material: Epoxy potting compound, resistant to most fuels, oils, acids, and cleaning agents.

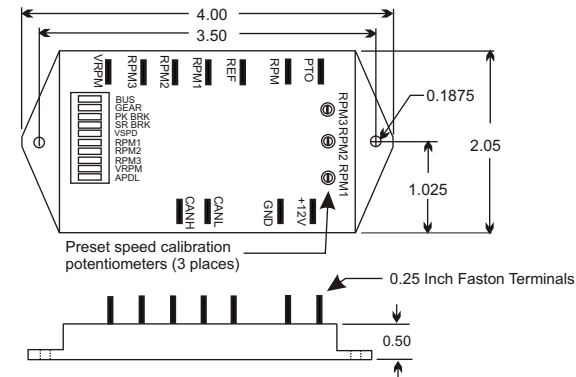

All dimensions in inches. Not to scale.

F. Customer Support

Technical Support

For product support, contact InPower at 740-548-0965 or 866-548-0965. Product bulletins and owner's manuals are available on our web site:

www.InPowerDirect.com.

Warranty

InPOWER LLC warrants its products to be free from defects in material and workmanship under normal use, care and maintenance for a period of two (2) years from the date of shipment. Please see www.inpowerdirect.com/warranty.htm for specifics or call 866-548-0965 for a copy of our warranty policy.

Customer Evaluation

InPower wants to ensure total customer satisfaction. Please download a product evaluation form at www.InPowerDirect.com/Customer_evaluation.htm or call us toll free at 866-548-0965 to be sent a form by mail.