

OWNERS MANUAL

InPower Model ITM118 Platform Lift Interlock 2005 - 2008 Ford E-Series Vehicles

Contents

1. Introduction	1
2. Product Description	1
3. Installation Procedures	1
4. System Circuit Diagrams	2
5. Wiring Instructions	4
6. Interlock System Operation.....	7
7. System Troubleshooting	7
8. Mechanical Drawings.....	8
9. Reference Information	8

1. Introduction

This product is intended for installation in 2005 thru 2008 Ford E-Series chassis with FMVSS compliant, public use platform lifts manufactured by The Braun Corporation, Ricon Corporation or Maxon Mobility. If another type of lift is to be used, contact the lift manufacturer to determine its compatibility.

This interlock system is designed to meet the requirements of FMVSS 403/404 and therefore must be installed in accordance with the lift manufacturer's instructions. The installer must be trained and skilled in installing FMVSS compliant lift systems. The installation must also comply with SAE (Society of Automotive Engineers) and Ford Motor Company electrical wiring procedures.

2. Product Description

The ITM118 interlock system consists of a control module, optional remote driver's LED display, and chassis interface wiring harness. The control module is a solid state, non-microprocessor-based control device. It contains two connectors for interfacing to the remote LED display and chassis interface wiring harness. It also contains six diagnostic LED indicators to aid in system troubleshooting. The chassis interface harness contains two "plug and play" tee-cables that connect to the parking brake switch and shift lock solenoid (located under the dash), as well as blunt-cut wires for interfacing to the platform lift system, door switch, transmission Park switch, and +12 volt power. There is also a flashing door output that can be used to power an indicator light to show when the lift door is ajar/open.

3. Installation Procedures

3.1 Safety Precautions



WARNING

This interlock product has been designed and manufactured to meet the intended application requirements and specifications. Any modifications to the product or to the installation procedure can be dangerous and will void InPower's warranty.

- Read and understand the instructions in this manual and other manuals before starting the installation.
- Make sure that the vehicle battery power is disconnected during installation of the Interlock and lift systems.
- Reconnect the battery when the system installation is complete.
- Wear appropriate safety equipment, such as protective eyeglasses, face shield and clothing when installing equipment and handling the battery.
- Be careful when working near a battery. Make sure that the area is well ventilated and that there are no flames near the battery. Never lay objects on the battery that can short the terminals together. If battery acid gets in your eyes, immediately seek first aid. If acid gets on your skin, immediately wash it off with soap and water.

3.2 Getting Started

This manual provides instructions for installing the InPower Model ITM118 Interlock System in a 2005 - 2008 Ford E-Series chassis with a FMVSS compliant, public use (commercial) platform lift. It is important that you follow these instructions carefully and contact InPower if you need assistance or more information. Note that product technical documents are available on InPower's web site.

! WARNING

Before installing and operating this interlock system, read and understand the lift manufacturer's safety, operating and installation instructions.

This interlock system installation requires additional parts and materials that are not supplied with the interlock product (See Section 9.2). Identify all required parts before starting the installation and ensure that these items are the correct type and quality.

Inspect the interlock product and all other components for damage before starting the installation. Do not perform the installation if any problems exist.

Determine the type of interlock interface required for the platform lift. This interlock system provides a +12 volt @ 10 amps *Lift Enable* output to allow the platform lift to be operated. It also requires a *Lift Stowed* signal from the lift system that is at ground when the lift is in the fully stowed position. If the lift system is not compatible with these two interface signals you must take the necessary actions to adapt the lift system interface to the interlock system's interface. Refer to the lift manufacturer's installation instructions for further details.

The recommended mounting location for the ITM118 interlock module is under the dash, to the left of the steering column due to the proximity of the wiring connections. **The unit must not be located in the engine compartment or any location that is not protected from the environment.**

4. System Circuit Diagrams

The following pages show the individual circuits that need to be wired. The following section, 5. *Wiring Instructions*, describes how to wire these circuits.

Interlock System Layout

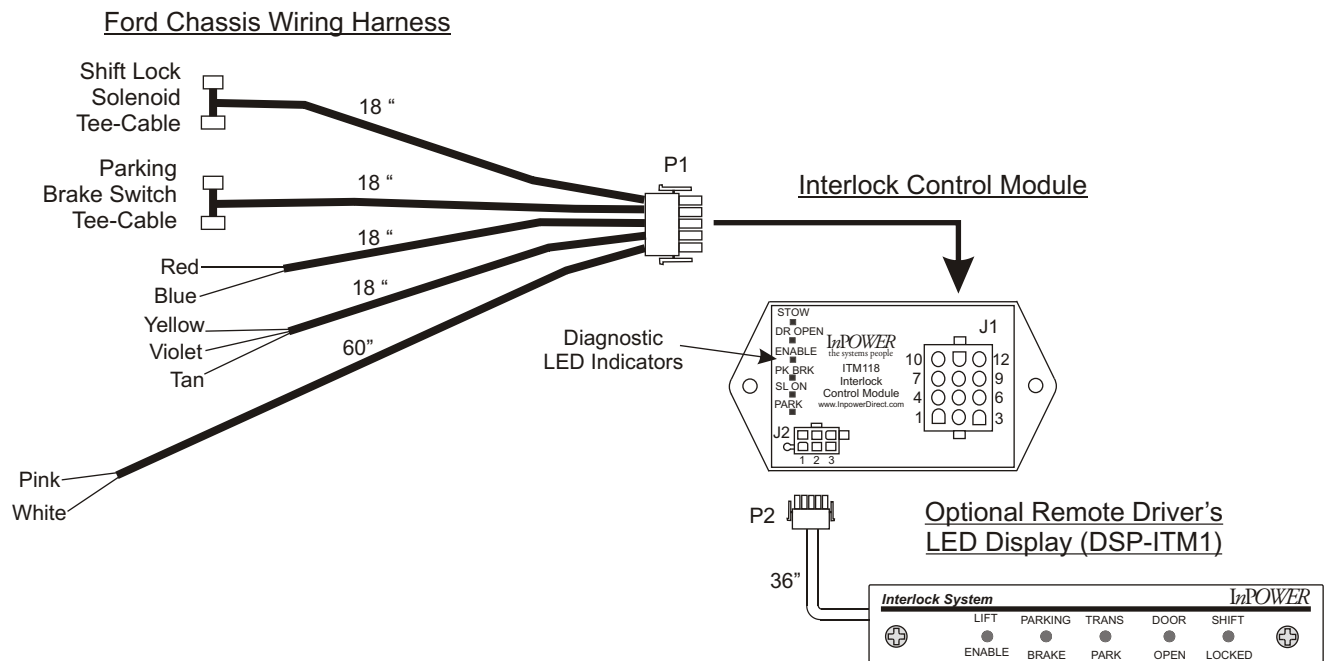

4. System Circuit Diagrams (Cont'd)

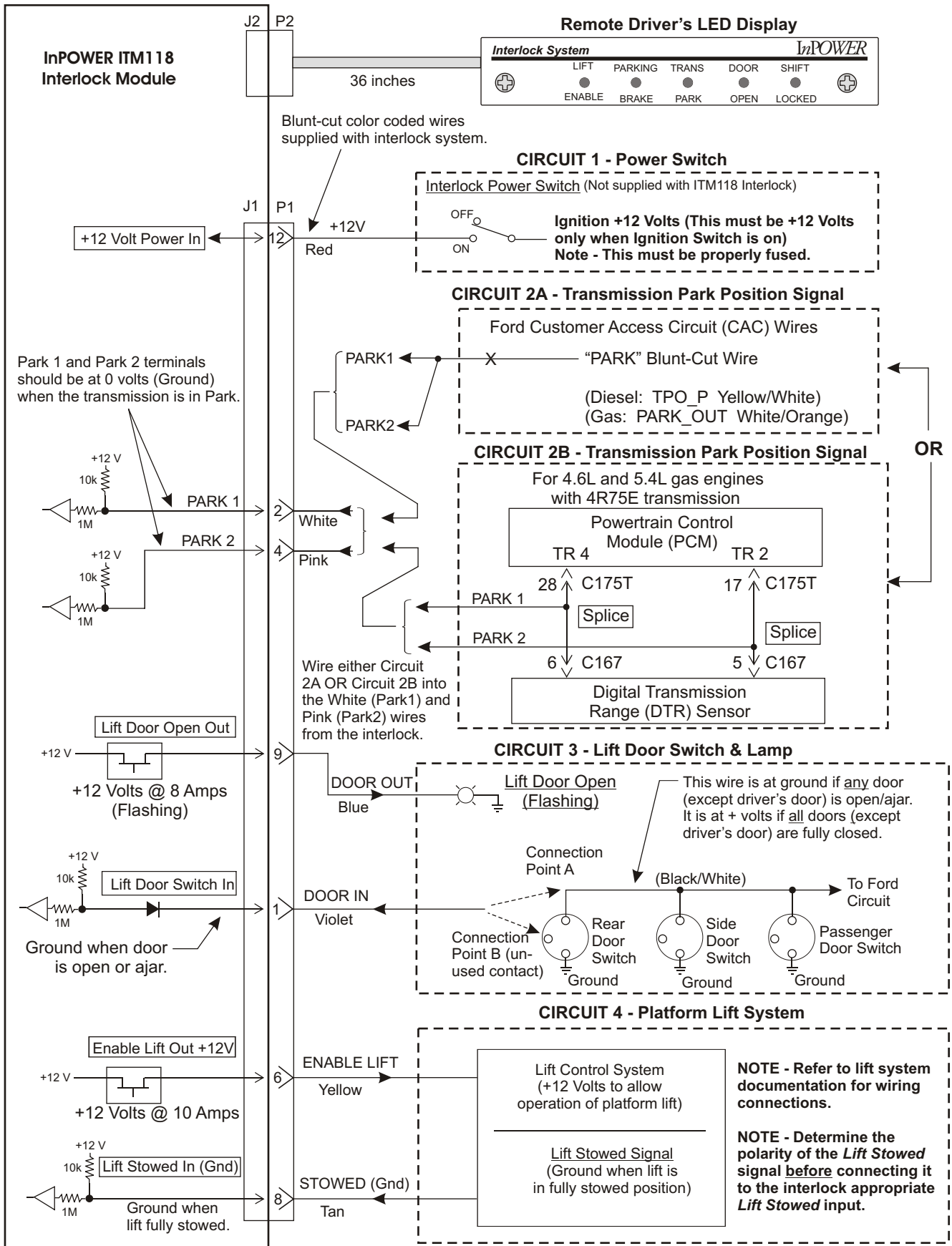

4. System Circuit Diagrams (Cont'd)

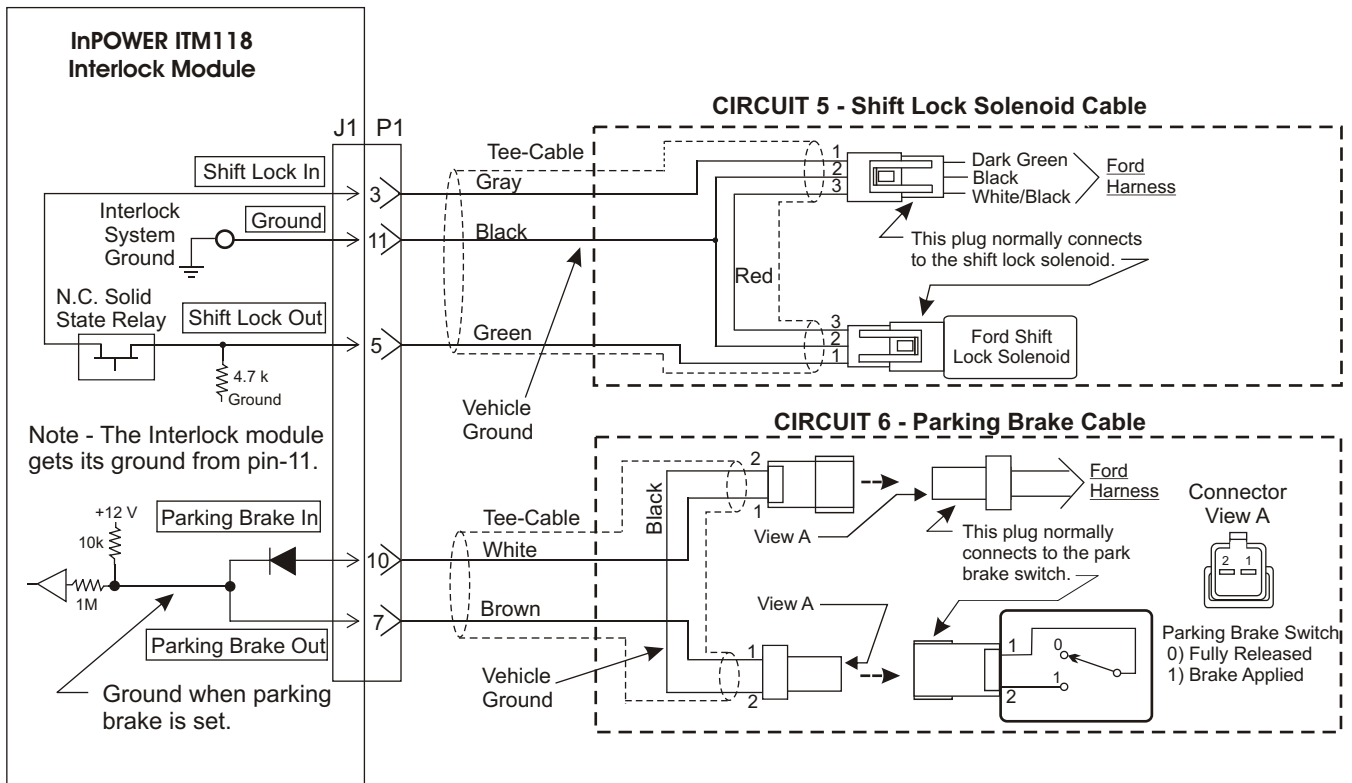

5. Wiring Instructions



WARNING

Make sure that the vehicle battery power is disconnected during installation of the Interlock and lift system. Reconnect the battery when the system installation is complete.

Circuit 1 Wiring (Interlock System Power Switch)

The installer must supply a two-position On-Off Interlock power switch capable of handling the combined current of the Lift Enable and Door Open/Ajar outputs. This switch may be mounted on the dash at a convenient location. NOTE - An alternative method is to wire the interlock module power input directly to a +12 volt fused power source that is powered by the Ignition Switch, and delete the Interlock Power Switch.

1. Mount the Interlock Power Switch.
2. Wire the "common" side of the Power On/Off switch to a properly fused +12 volt ignition switch source (**powered when the ignition switch is On**). Refer to the Ford documentation for location of customer access ignition circuits.
3. Wire the "On" position side of the switch to the Red harness wire that goes to pin 12 on the interlock module.
4. When complete, you should have +12 volt fused power on the interlock module pin 12 when the ignition switch is On and the Interlock Power Switch is On.

NOTE - Do not power the interlock system directly from the Battery or any power source that is not fused and turned off with the ignition switch.

Circuit 2 (Transmission Park Position)

There are two ways to wire to the transmission Park position signal, depending on the chassis type. The recommended method is Circuit 2A, and this requires the vehicle to have the *Ford Stationary Elevated Idle Control (SEIC)/Customer Access Circuits (CAC)* feature. If your vehicle does not have the SEIC/CAC feature, refer to Circuit 4B (These are usually vans with gas engines and 4-speed automatic transmission).

5. Wiring Instructions (Continued)

Circuit 2A (Vehicles With SEIC/CAC Park Wire)

The Ford PARK position signal is a blunt-cut wire that is supplied as part of the Ford *Stationary Elevated Idle Control* (SEIC) and *Customer Access Circuits* (CAC) feature. This blunt-cut wire is located in the engine compartment on the top driver's side of the firewall. It is in the large harness running below the windshield/ cowl. Refer to Ford's Body Builders Layout Book for further details relating to the Ford SEIC and Customer Access signals.

1. Locate the blunt-cut wire #1857 (On gas engine it is a White/Orange wire tagged: "PARK_OUT"; on diesel engines it is a Yellow/White wire tagged: "TRO_P") in the large wire harness running below the windshield/cowl in the engine compartment. Remove some of the plastic harness tape where the harness exits its plastic support gutter above the engine air induction tube to reveal the blunt-cut wires.
2. Route the Park 1 (White) and Park 2 (Pink) wires (they are 60 inches long) from the ITM118 wiring harness through the firewall to the blunt-cut wire #1857. Splice the Park 1, Park 2 and wire #1857 together. Note - Alternatively, you can use the Ford pass-through wires that run from the engine compartment into the cab above the driver-side kick panel. All under hood splices must be sealed and insulated. For proper procedure, refer to the Electrical Wiring General Practices section of the Ford Body Builders Layout Book.

Circuit 2B Vehicles Without SEIC/CAC Park Wire

Note - Refer to Ford's Body Builders Layout Book for instructions dealing with pass-through wires and under the hood wire splices.

1. Locate the Powertrain Control Module (PCM) connector C175T. This will be on the driver's side of the firewall in the engine compartment.
2. Locate the TR 4 wire (Circuit #1146 - Lt. Green/Red) on pin 28 of connector C175T. See Figures 1 & 2 for connector pin layout and Circuit 2B for circuit reference.
3. Splice into this wire with the ITM118 wire harness White wire that goes to pin 2 on the ITM118 module.
4. Locate the TR 2 wire (circuit #1145 - Lt. Blue/Black) on pin 17 of connector C175T.
5. Splice into this wire with the ITM118 wire harness Pink wire that goes to pin 4 on the ITM118 module.

NOTE - Protect all under hood wiring with corrugated loom (convoluted tubing).

Figure 1
Powertrain Control Module (PCM)

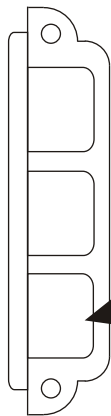
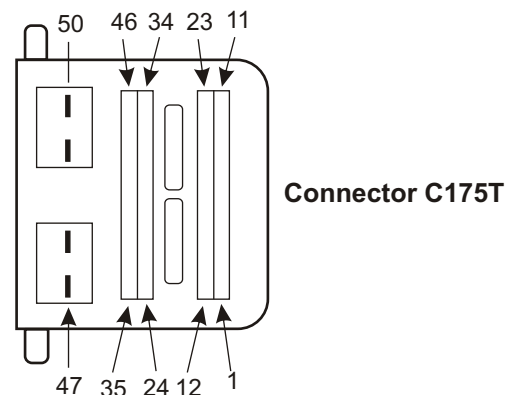

Figure 2
View Looking Into the Transmission
Connector Showing Pin Numbers



Circuit 3 (Lift Door Switch and Light)

Wire the switch as shown in the Circuit #3 diagram. Install a wire from the interlock wiring harness Violet wire that goes to pin1 on the interlock control module to either Connection Point A on the door switch or to Connection Point B. If wired to A, the rear, side and passenger doors interact to provide the following operation. If any door is opened the lift can be operated (providing the vehicle is in Park and park brake is set). And all doors (except the driver's door) must be closed to complete the interlock sequence (release the shift lock). If wired to Connection Point B, only the door switch wired will be monitored by the interlock system. Note that you will need a switch connector pin to attach to the switch when using Connection Point B.

5. Installation Instructions (Continued)

Circuit 4 Wiring (Platform Lift)

1. Review the platform lift installation manual and determine how to wire the ITM118 interlock system to the following lift interface connections:

A. Enable Lift - This is an **input** to the lift system. When at +12 volts, the platform lift can be operated. Install a wire from the platform lift's *Enable Lift* input to the ITM118 Yellow blunt-cut wire that goes to pin 6.
Interlock module.

Note - The ITM118 will supply a +12 volt @ 10 amp output to allow operation of the lift. Verify that this is the correct polarity for the platform lift.

B. Lift Stowed - This is an **output** from the lift system. **Verify the polarity of this signal.** It should be a ground signal when the lift in the fully stowed position. Wire it to the ITM118 Tan blunt-cut wire that goes to pin 8.

The following diagrams show the wiring interface of typical platform lift systems. **Be sure to verify the exact wiring interface for the lift system that you have.**

Braun FMVSS Platform Lifts

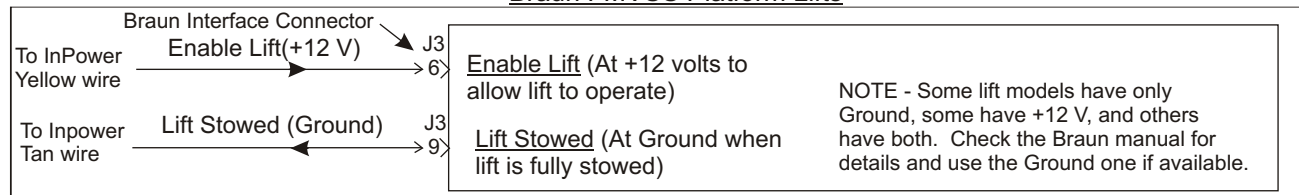

Ricon Series S Platform Lifts

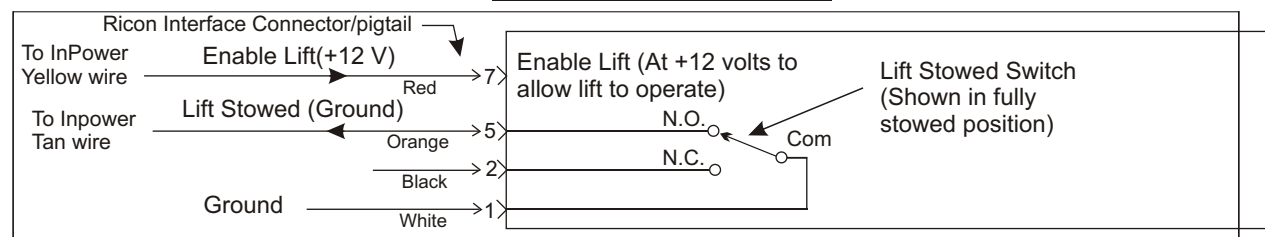

Maxon Platform Lifts

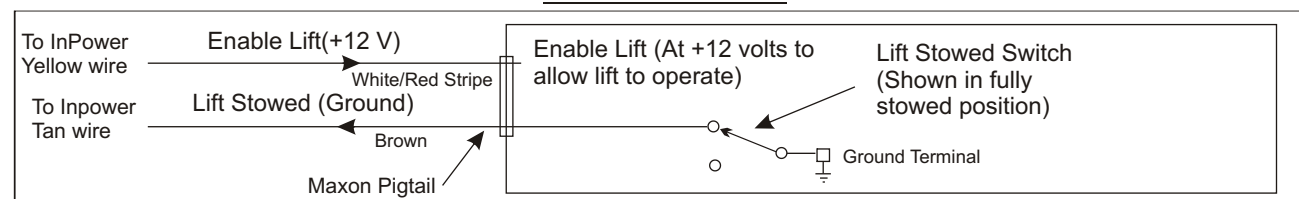

Circuit 5 Wiring (Shift Lock Solenoid Cable)

1. Locate the shift lock solenoid that is on the bottom left of the steering column behind the dash panel. It has a three-wire harness plugged into it.
2. Remove the harness plug from the solenoid assembly.
3. Install the tee-cable supplied with the interlock between the solenoid connector and the harness plug that you removed from the solenoid. When complete, the interlock tee-cable will be connected to the Ford harness plug and the shift lock solenoid as shown in Circuit #5 diagram.

Circuit 6 Wiring (Parking Brake Switch Cable)

1. Locate the Parking Brake Switch connector C2015 that is near the parking brake pedal assembly. It has a two-wire harness plugged into it.
2. Remove the harness plug from the switch connector.
3. Install the tee-cable supplied with the interlock wiring harness between the parking brake switch connector and the harness plug that you removed from the parking brake switch connector.
4. When complete, the interlock tee-connector will be connected to the Ford harness plug and to the parking

5. Wiring Instructions (Continued)

Remote Driver's LED Display (Optional)

The LED display includes a 36 inch cable that is attached to the underside of the display at one end and contains a 6-pin connector plug at the other end. Mount the display in a suitable location on the dash (usually to the right of the steering wheel). Two methods may be used for routing the cable. It may exit the side of the display so that it can be routed between the dash panel and the steering column. Or, you can drill a hole in the dash so that the cable can be routed through and behind the dash. Attach the display with the to mounting screws provided, route the cable to the interlock control module, and insert the cable plug into connector J2.

NOTE - Consult Ford documentation before drilling to verify the location of all critical components and harnesses.

6. Interlock System Operation

The interlock system is powered from the Interlock Power Switch and the Ignition Switch when they are both in the On position. The following is the interlock system sequence of operation:

- Step 1 - With the interlock powered on, place the transmission in the Park position.
- Step 2 - Set the parking brake.
- Step 3 - Open the lift door. When opened, the transmission shift lock will be set to prevent the transmission from being taken out of Park, and the Lift Enable will be set to allow operation of the platform lift. The Lift Door Open light, if installed, will operate.
- Step 4 - The platform lift may now be operated (Refer to the platform lift operating instructions). Note - During the Lift Enable sequence, if the parking brake is released the Lift Enable will be deactivated, preventing lift operation.
- Step 5 - When the lift cycle is completed return the lift to its fully stowed position.
- Step 6 - Close the lift door. Note - Depending on how the door switch is wired, all doors may need to be closed.
- Step 7 - Release the parking brake. When released, the shift lock will be automatically released.
- Step 8 - The cycle is now complete and the vehicle can be taken out of Park and driven.

Notes:

- 1. The Lift Door Open output (+12 v @ 10 amps) is activated whenever the door is open, independent of other interlock inputs.

7. System Troubleshooting

If there is a problem with system operation, there is a very high probability that the control module has: A) either lost its ground or +12 volt power source, or B) that one or more of its inputs are not being actuated by the remote sensor (e.g., Lift Door Switch or Lift Stowed Switch). Most troubles are related to wiring problems, or sensors either failing or becoming out of adjustment.

Troubleshooting Procedure:

- Step 1 - Determine if the control module is powered. If the LEDs on the control module are illuminated you have power. If none are illuminated, check the +12 volt supply on +12V terminal with a voltmeter. Also check that the module is getting a good ground on pin 11 of connector J1
- Step 2 - If the ground and power are correct, first reset the interlock system by turning off its power. Then, step through the operating sequence as described in Section 6. *Interlock System Operation*, and note the status of the green and red LED indicators on the control module. Pay particular attention to the inputs (Green LEDs) such as the lift door switch input and the lift stowed switch input. Verify that the input status LEDs agree with the sensor positions.

The interlock control module contains six diagnostic LED indicators to aid in system troubleshooting. These indicators show the status of input and output signals of the control module, and are color coded as follows: Input Signals = Green and Output Signals = Red. These diagnostic indicators are located on the connector side of the module.

7. System Troubleshooting (Cont'd)

System Diagnostic LED Indicators (Located on the Control Module)

- STOW (Green) On when the platform lift is the fully stowed position.
- DR OPEN (Green) On when the platform lift door is ajar or open (not fully closed).
- ENABLE (Red) On when the interlock allows the platform lift to operate.
- PK BRK (Green) On when the park brake is set.
- SL ON (Red) On when the interlock system is locking the shifter in the park position.
- PARK (Green) On when the transmission is in the Park position.

8. Mechanical Drawing

Model ITM118 Control Module

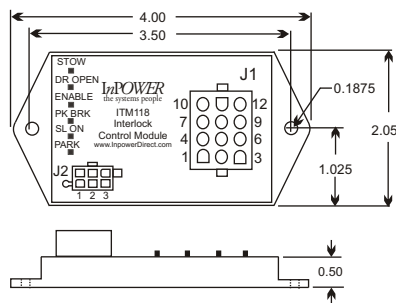

Driver's LED Display

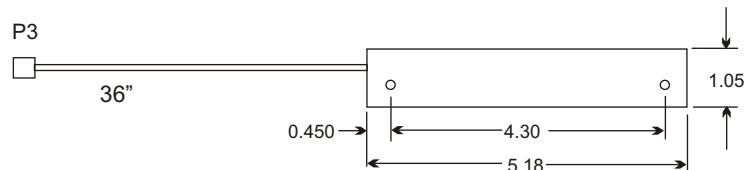

All dimensions in inches. Not to scale.

9. Reference Information

9.1 Company Contacts

Ford Motor Company

Truck Body Builder Advisory Service
Product Development Center
MD 410
PO Box 2053
Dearborn, MI 48121-2053
1-877-840-4338
www.fleet.ford.com/truckbbas/index.htm
bbasqa@ford.com

The Braun Corporation

631 West 11th Street
Winamac, IN 46966
(574) 946-6153
(800) 946-6158
www.braunlift.com

Ricon Corporation

7900 Nelson Road
Panorama City, CA 91402
(818) 267-3038
(800) 322-2884
www.riconcorp.com

Maxon Lift Corp.

11921 Slauson Avenue
Sante Fe Springs, CA 90670
(562) 464-0099
(800) 227-4116
www.maxonlift.com

9.2 Required Parts Not Supplied with ITM118 Interlock System

1. Power switch and fuse. See page 3, Circuit 1.
2. Lift Door Open indicator light, if required. See page 3, Circuit 3.
3. Lift Door Closed switch, if not using Ford door switch. See page 3, Circuit 3.
4. Miscellaneous wire, mounting hardware, wire tie wraps, wire loom.