

G. Mechanical Drawing

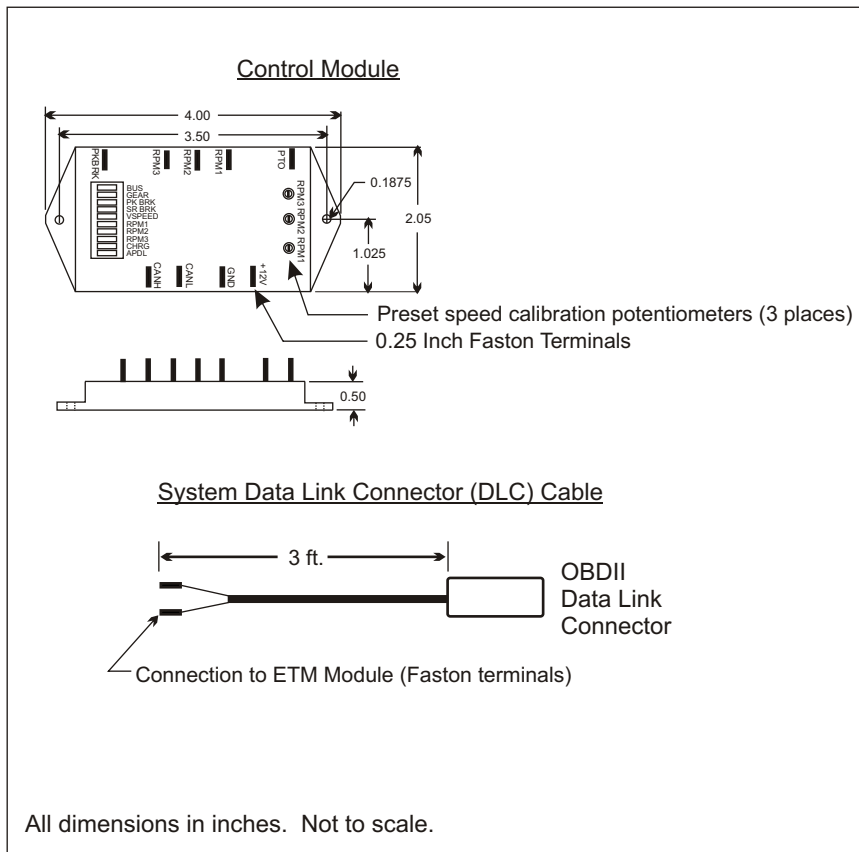

InPOWER

the systems people

InPOWER LLC
3555 Africa Road
Galena, Ohio 43021 U.S.A
(740)548-0965
www.InPowerDirect.com

Owners Manual

Document: OM-64
Date: Oct. 3, 2007
Revision: E
Date: June 11, 2010

OWNERS MANUAL

**Model ETM67A & ETM68A
Electronic Throttle Module
for 2006 through 2010
Chevy/GMC Gas and Diesel Engines
with Automatic Transmissions**

A. Introduction

This owners manual describes the InPower Model ETM67A and ETM68A electronic throttles used on Chevy & GMC vehicles with gas and diesel engines. Note that the ETM67A and ETM68A systems support the exact same vehicles, but differ only in functionality. The ETM68A provides three fast idle preset speed modes (RPM1, RPM2 & RPM3). The ETM67A provides three fast idle preset speed modes (RPM1, RPM2 & RPM3) plus a *Charge Protect* (CHRG) mode.

The electronic throttle installation requires customer-supplied control wiring to select the required mode of operation. For example, a remote toggle switch or a relay contact from a compressor or aerial lift circuit could be wired to the RPM1 terminal on the electronic throttle controller to activate the RPM1 fast idle mode. The RPM1 mode is then adjusted to the desired fast idle engine speed rpm. Likewise, the RPM2 and RPM3 mode inputs could be wired if you need additional fast idle engine speed functions.

The customer wiring connects to the electronic throttle module via 0.25 inch Faston terminals. The electronic throttle system is supplied with a three foot data cable. This cable contains a 16-pin connector at one end and 0.25 inch Faston terminals at the other end. The Faston terminals will connect at the electronic throttle module and the 16-pin connector plug will attach to the vehicle's OBDII (On Board Diagnostic) data link connector (DLC). The DLC is usually located at the lower part of the dash on the driver's side.

InPOWER

InPOWER

B. Vehicle Applications

The ETM67A and ETM68A support the following GM vehicle configurations.

| Model Year | Chassis | Engine | Transmission |
|-------------------------------------|---------------------------------------|----------------------------------|--------------|
| 2006, 2007, 2007i, 2008, 2009, 2010 | Silverado/Sierra Classic C2500, C3500 | 6.6 L Diesel | Automatic |
| 2007i, 2008, 2009 | Silverado/Sierra Classic C2500, C3500 | 6.0 L Gas | Automatic |
| 2006, 2007, 2007i, 2008, 2009 | Kodiak/Topkick C4500, C5500 | 6.6 L Diesel | Automatic |
| 2006 - 2010 | Express, Savanna | 6.6 L Diesel, 4.8 L & 6.0 L Gas | Automatic |
| 2007 - 2010 | Tahoe/Suburban/Yukon | 4.8 L, 5.3 L, 6.0 L, & 6.2 L Gas | Automatic |

C. Operation

When the vehicle is parked and **Chassis Ready Conditions** are satisfied, the engine speed may be controlled by one of the three available preset speed modes. The preset speed is adjusted by three calibration potentiometers on the top of the ETM module.

Chassis Ready Conditions:

1. Parking brake is set.
2. Gear shift in "Park"
3. Foot is off the service brake
4. Foot is off the accelerator pedal
5. Vehicle is stationary (no speed)
6. Engine is started and idling below 1000 RPM

Modes Of Operation:

1. Three Preset RPM High Idle Modes:

| | |
|-----------------------|--|
| Function: | Increase idle to a preset rpm value |
| Terminals: | RPM1, RPM2, RPM3 |
| Activation: | Apply +12 V to terminal |
| Range of Calibration: | 650 to 1460 rpm (Diesel), 650-2000 rpm (Gas) |
| Type of Adjustment: | Internal potentiometers |

InPOWER

F. Wiring Diagram

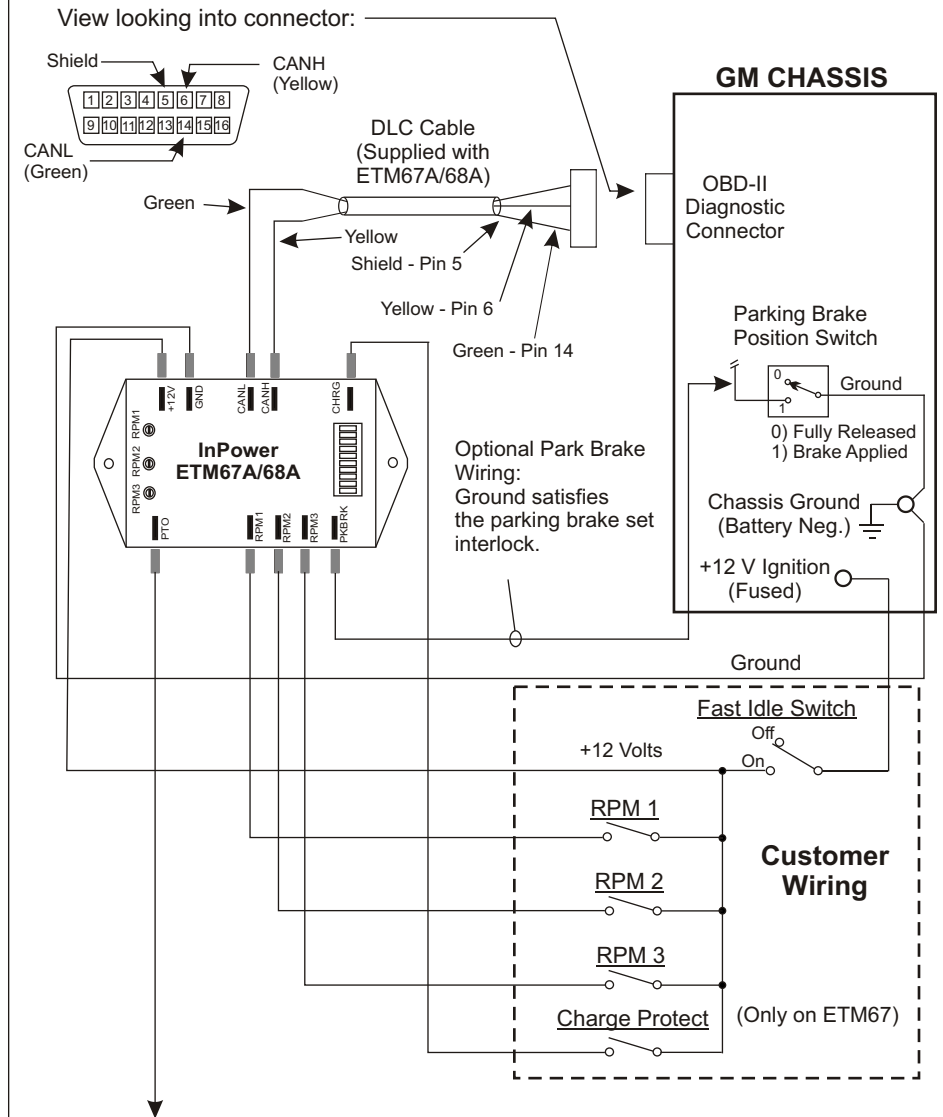

PTO output is +12 volts at 3 amps and is set when the throttle control is actively controlling the engine rpm and the Chassis Ready Conditions are satisfied. **Do not connect any +12 volt sources to this output terminal or damage may result voiding the warranty.**

InPOWER

D. Installation (Continued)

5. PTO Enable Wiring - Diesel Engines Only (Continued)

On 2009-2010 Gvans there is no *PTO Enable* function so the following procedure must be used when going to high idle:

- | | |
|--------|-------------------------------------|
| Step 1 | Turn on the Cruise Control |
| Step 2 | Turn on the ETM67A/68A |
| Step 3 | Press the Cruise Control Set button |

6. Wire the Mode Selection Controls

The following wiring is required by the customer to select the operating modes required to run the ETM system. You will need to supply contact closures such as a toggle switch or relay contact to supply +12 volts at the ETM module's terminals for the required preset rpm modes (RPM1, RPM2, RPM3 or CHRГ). **It is important that the +12 volts used to feed the mode select terminals is from the Ignition Switch power source, and it should be properly fused. That is, it must be +12 volts when the Ignition Switch is On, and zero volts when the Ignition Switch is Off.**

7. Wire the Power and Ground

Install a wire from a good ground (battery negative) to the GND terminal on the ETM67A/68A module. Install a Fast Idle Switch (not supplied with ETM system) and wire one side of the switch to a source of +12 volts that is fused and only powered when the ignition switch is in the On position. Wire the other side of the switch to the +12V terminal on the ETM module and to the contacts that select the RPM1, RPM2 & RPM3 modes (see diagram on page 4).

E. Setup and Calibration

The only calibration required is the speed rpm setting for the three preset rpm modes (RPM1, RPM2 & RPM3). To perform the calibration activate the desired preset mode, then adjust the respective speed calibration potentiometer (RPM1, RPM2 or RPM3) for the required speed. **NOTE - The calibration potentiometers are located on the top of the module in recessed holes. Take care to use a proper size screwdriver (3/64" / 1.5mm) or damage to the potentiometers may result, voiding the warranty.**

C. Operation (Continued)

2. Mode Priorities:

A mode priority selection scheme is provided that will eliminate conflicts if more than one mode is selected at a time. In the case of one or more modes being selected, the following priorities will be established:

| | |
|------|---|
| RPM1 | Highest - Will override all other modes |
| RPM2 | Second - Will override lower modes |
| RPM3 | Third - Will override lower mode |
| CHRG | Fourth |

3. Charge Protect Mode (Only on ETM67A):

| | |
|-------------------------|---|
| Function: | Varies rpm to maintain battery charge voltage |
| Control Terminal: | CHRG |
| Activation: | Apply +12V to CHRG terminal |
| RPM Range: | 900 to 1700 rpm |
| Battery Voltage Levels: | 13.3 Vdc Increase rpm; 13.5 Vdc Decrease rpm |

Status Indicators

A 10 segment LED provides status and problem detection information. Refer to the following table for coding of these functions.

NOTE - These LED indicators will only be powered when a Mode (RPM1, RPM2, RPM3, CHRG) is selected.

| LED | Status | Indication |
|--------|----------|--|
| BUSS | On Solid | Module ON and functioning |
| BUSS | Flashing | Module ON, but a problem was Detected with Data Buss |
| GEAR | On Solid | Transmission in PARK position |
| GEAR | Flashing | Transmission not in PARK position |
| PK BRK | On Solid | Park Brake set |
| PK BRK | Flashing | Park Brake not set |
| SR BRK | On Solid | Service Brake off |
| SR BRK | Flashing | Service Brake applied |
| VSPEED | On Solid | Vehicle is stationary |
| VSPEED | Flashing | Vehicle is moving |

Continued...

C. Operation (Continued)

| LED | Status | Indication |
|------|----------|--|
| RPM1 | On Solid | RPM1 mode selected, engine at fast idle |
| RPM1 | Flashing | RPM1 mode selected, engine not at fast idle (Chassis Ready Conditions not satisfied*) |
| RPM2 | On Solid | RPM2 mode selected, engine at fast idle |
| RPM2 | Flashing | RPM2 mode selected, engine not at fast idle (Chassis Ready Conditions not satisfied*) |
| RPM3 | On Solid | RPM3 mode selected, engine at fast idle |
| RPM3 | Flashing | RPM3 mode selected, engine not at fast idle (Chassis Ready Conditions not satisfied*) |
| CHRG | On Solid | Charge Protect mode selected |
| CHRG | Flashing | Charge Protect mode selected, engine not at fast idle (Chassis Ready Condition not satisfied*) |

Note - If all of the LED lights are flashing this indicates either a faulty DLC Cable connection or that this ETM67A/ETM68A version is not compatible with the chassis.

* See *Chassis Ready Conditions* on page 2 for required conditions to allow increased idle speed.

D. Installation

1. Getting Started

The recommended location for the ETM system is under the dash due to the proximity of the wiring connections and cable length. **The unit should not be located in the engine compartment, or any location that is not protected.** You will need a crimping tool for the 0.25 inch Faston (blade) terminals, and a wire stripping tool. Be sure to follow the crimping tool instructions for the proper wire size and terminals.

2. Mount the ETM Module

Mount the ETM module under the dash using the two mounting holes. Ensure that you have sufficient distance to install the 36 inch long DLC cable. **DO NOT EXTEND THE LENGTH OF THIS CABLE OR WARRANTY WILL BE VOIDED.**

D. Installation

3. Install the DLC Cable

Connect the two Faston terminals on the DLC cable to the ETM module terminals (Green wire to CANL terminal and Yellow wire to CANH terminal). Route the cable to the OBDII (On Board Diagnostic) Data Link Connector and plug it in. The OBDII connector will be located on the lower part of the dash on the driver's side. Using a cable tie, secure the plug to the OBDII connector so that it will not vibrate out. We recommend that you route the cable of the plug back across the bottom of the connector and loop the cable tie around the plug, socket and cable, thereby keeping the cable out of the way. Also ensure that the entire cable is routed and secured to keep it out of the way.

4. Wire the Parking Brake Switch Input

Note - Follow this procedure ONLY for the following chassis configurations:

- 2006, 2007 Silverado/Sierra Classic C2500, C3500 with 6.6 L Diesel
- 2006 - 2008 Kodiak/Topkick C4500, C5500 with 6.6 L Diesel
- 2006, 2007 Express, Savanna with 6.6 L Diesel

The ETM67A/68A systems requires an input to detect that the parking brake is set before it can go to fast idle (only on the indicated models). Install a wire from the PK BRK terminal on the ETM module to the chassis parking brake switch. Connect this wire on the side of the switch that is not grounded. Verify that the wiring is correct by measuring the voltage at the PK BRK terminal when the parking brake is operated. The terminal should be at ground when the brake is depressed and at + voltage when not depressed.

5. PTO Enable Wiring - Diesel Engines Only

On 2007 and earlier chassis it is necessary to activate the *PTOEnable* input function on the Engine Control Module (ECM) when going to high idle. There are different methods of activating this function depending on the chassis configuration. See InPower Technical Bulletin TB-59 for details.