

OWNERS MANUAL

Model ETM80 Electronic Throttle Module for 2007 through 2008 Dodge RAM Trucks with 6.7L Cummins Diesel V8 Engine with Automatic Transmissions

InPower Document OM-69A

CAUTIONARY NOTES

1. Do not drive vehicle with ETM80 activated or with 12V applied to any of the RPM1, RPM2, or RPM3 terminals.

2. Do not disconnect or turn off the 12V applied to the 12V terminal until the 12V has been removed from the RPM1, RPM2, and RPM3 terminals and the engine rpm has returned to idle.

3. Do not connect 12V to the ETM80 PTO Terminal. This terminal is a +12 volt output. Connecting a 12 volt power source to this terminal may cause permanent damage to the ETM80.

A. Introduction

This owners manual describes the InPower Model ETM80 electronic throttles used on Dodge vehicles with diesel engines. The ETM80 provides three fast idle preset speed modes (RPM1, RPM2, & RPM3).

The electronic throttle installation requires customer-supplied control wiring to select the required mode of operation. For example, a remote toggle switch or a relay contact from a compressor or aerial lift circuit could be wired to the RPM1 terminal on the electronic throttle controller to activate the RPM1 fast idle mode. The RPM1 mode is then adjusted to the desired fast idle engine speed rpm. Likewise, the RPM2 and RPM3 mode inputs could be wired if you need additional fast idle engine speed functions.

The customer wiring connects to the electronic throttle module via 0.25 inch Faston terminals. The electronic throttle system is supplied with a three foot data cable. This cable contains a 16-pin connector at one end and 0.25 inch Faston terminals at the other end. The Faston terminals will connect at the electronic throttle module and the 16-pin connector plug will attach to the vehicle's OBDII (On Board Diagnostic) data link connector (DLC). The DLC is usually located at the lower part of the dash on the driver's side.

InPOWER

B. Vehicle Applications

The ETM80 supports the following Dodge vehicle configurations.

<u>Model Year</u>	<u>Chassis</u>	<u>Engine</u>	<u>Transmission</u>
2007, 2008	RAM 1500 - 3500	6.7L Cummins Diesel	Automatic
2008	RAM 4500 - 5500	6.7L Cummins Diesel	Automatic

C. Operation

When the vehicle is parked and **Chassis Ready Conditions** are satisfied, the engine speed may be controlled by one of the three available preset speed modes. The preset speed is adjusted by three calibration potentiometers on the top of the ETM module.

Chassis Ready Conditions:

1. Parking brake is set.
2. Gear shift in "Park"
3. Foot is off the service brake
4. Foot is off the accelerator pedal
5. Vehicle is stationary (no speed)
6. Engine is started and idling below 1000 RPM

Modes Of Operation:

1. Three Preset RPM High Idle Modes:

Function:	Increase idle to a preset rpm value
Terminals:	RPM1, RPM2, RPM3
Activation:	Apply +12 V to terminal
Range of Calibration:	900 to 2000 rpm
Type of Adjustment:	Internal potentiometers

2. Mode Priorities:

A mode priority selection scheme is provided that will eliminate conflicts if more than one mode is selected at a time. In the case of one or more modes being selected, the following priorities will be established:

RPM1	Highest - Will override all other modes
RPM2	Second - Will override lower modes
RPM3	Third - Will override lower mode

Status Indicators

A 10 segment LED provides status and problem detection information. Refer to the following table for coding of these functions. **NOTE - These LED indicators will only be powered when a Mode (RPM1, RPM2, RPM3) is selected.**

LED	Status	Indication
BUSS	On Solid	Module ON and functioning
BUSS	Flashing	Module ON, but a problem was detected with Data Buss
GEAR	On Solid	Transmission in PARK position
GEAR	Flashing	Transmission not in PARK position
PK BRK	On Solid	Park Brake set
PK BRK	Flashing	Park Brake not set
SR BRK	On Solid	Service Brake off
SR BRK	Flashing	Service Brake applied
VSPEED	On Solid	Vehicle is stationary
VSPEED	Flashing	Vehicle is moving
RPM1	On Solid	RPM1 mode selected, engine at fast idle
RPM1	Flashing	RPM1 mode selected, engine not at fast idle (Chassis Ready Conditions not satisfied*)
RPM2	On Solid	RPM2 mode selected, engine at fast idle
RPM2	Flashing	RPM2 mode selected, engine not at fast idle (Chassis Ready Conditions not satisfied*)
RPM3	On Solid	RPM3 mode selected, engine at fast idle
RPM3	Flashing	RPM3 mode selected, engine not at fast idle (Chassis Ready Conditions not satisfied*)
APDL	On Solid	Accelerator pedal at rest position
APDL	Flashing	Accelerator pedal actuated (not at rest position)

D. Installation

1. Getting Started

The recommended location for the ETM system is under the dash due to the proximity of the wiring connections and cable length. **The unit should not be located in the engine compartment, or any location that is not protected.** You will need a crimping tool for the 0.25 inch Faston (blade) terminals, and a wire stripping tool. Be sure to follow the crimping tool instructions for the proper wire size and terminals.

2. Mount the ETM Module

Mount the ETM module under the dash using the two mounting holes. Ensure that you have sufficient distance to install the 36 inch long DLC cable. **DO NOT EXTEND THE LENGTH OF THIS CABLE.**

3. Install the DLC Cable

Connect the two Faston terminals on the DLC cable to the ETM module terminals (Green wire to CANL terminal and Yellow wire to CANH terminal). Route the cable to the OBDII (On Board Diagnostic) Data Link Connector and plug it in. The OBDII connector will be located on the lower part of the dash on the driver's side. Using a cable tie, secure the plug to the OBDII connector so that it will not vibrate out. We recommend that you route the cable of the plug back across the bottom of the connector and loop the cable tie around the plug, socket and cable, thereby keeping the cable out of the way. Also ensure that the entire cable is routed and secured to keep it out of the way.

4. Optional Parking Brake Switch Input

The Park Brake Input Terminal on ETM80 system is not required for normal usage. It is provided for applications that need to increase the engine idle with the Parking Brake Released. Grounding this terminal will allow the ETM80 to function with the Parking Brake Released.

5. PTO Enable Wiring

The ETM80 PTO Output Terminal provides +12V@ 3A to activate a PTO relay. This output turns on after all the interlock conditions are met and the engine rpm has been increased to 900rpm. After this output turns on there is a 1 second delay before the engine rpm ramp up begins. This allows the PTO to completely engage at 900 rpm. **Do NOT connect this terminal to the PCM PTO input terminal. The PCM rpm controls will override the ETM80 settings. Do NOT connect any 12V sources to this output terminal, permanent damage to the ETM80 will result.**

6. Wire the Mode Selection Controls

The following wiring is required by the customer to select the operating modes required to run the ETM80 system. You will need to supply contact closures such as a toggle switch or relay contact to supply +12 volts at the ETM80 module's terminals for the required preset rpm modes (RPM1, RPM2, or RPM3). **It is important that the +12 volts used to feed the mode select terminals is from the Ignition Switch power source, and it should be properly fused. That is, it must be +12 volts when the Ignition Switch is On, and zero volts when the Ignition Switch is Off.**

7. Wire the Power and Ground

Install a wire from a good ground (battery negative) to the GND terminal on the ETM80 module. Install a Fast Idle Switch (not supplied with ETM system) and wire one side of the switch to a source of +12 volts that is fused and only powered when the ignition switch is in the On position. Wire the other side of the switch to the +12V terminal on the ETM module and to the contacts that select the RPM1, RPM2, & RPM3 modes (see diagram on page 5).

E. Setup and Calibration

The only calibration required is the speed rpm setting for the three preset rpm modes (RPM1, RPM2, & RPM3). To perform the calibration activate the desired preset mode, then adjust the respective speed calibration potentiometer (RPM1, RPM2, or RPM3) for the required speed. **NOTE - The calibration potentiometers are located on the top of the module in recessed holes. Take care to use a proper size screwdriver (3/64" / 1.5mm) or damage to the potentiometers may result.**

F. Wiring Diagrams
F.1 General Wiring

Figure 1

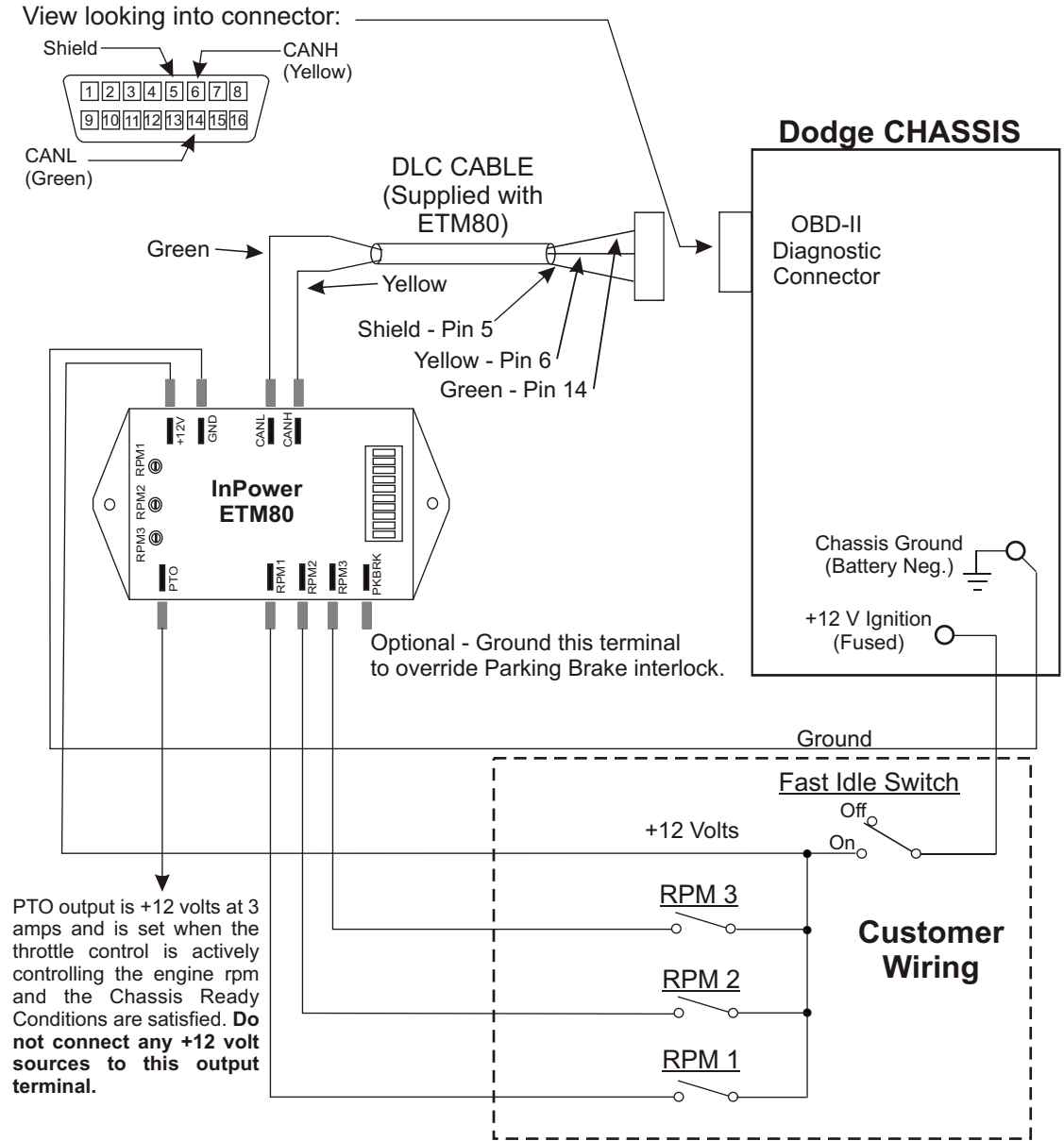

Required Tools and Parts not provided with ETM80

1/4 inch Female Blade Terminal
 Wire rated for under-hood temperatures
 Convoluted tubing or braided mesh wire covering
 Small flat bladed tool

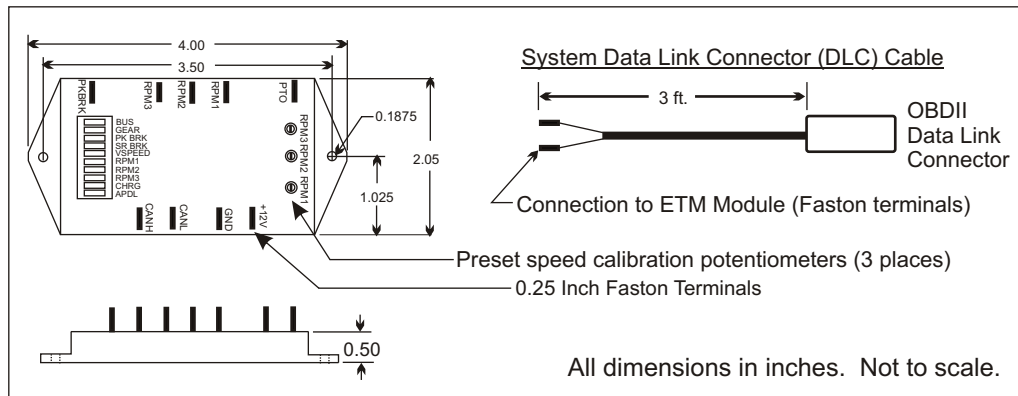
E. Mechanical Drawing

InPOWER
 the systems people
 InPOWER LLC
 3555 Africa Road
 Galena, Ohio 43021 U.S.A
 (740)548-0965
 www.InPowerDirect.com

Owners Manual

Document: OM-69A
 Date: May 1, 2008
 Version Code: A
 Date: APRIL 8, 2008

InPOWER