

OWNERS MANUAL

Ambulance Module Power Disconnect Switch

Model SSC42-275
Model SSC42A-275
Model SSC42B-275

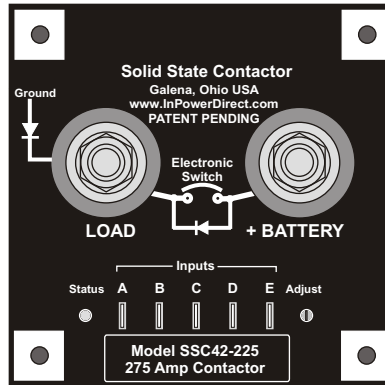

1. Introduction

The InPower Ambulance Module Power Disconnect Switch is intended for use in ambulances to disconnect battery power from module loads such as emergency lights, patient compartment lights, flood lights, loading lights, etc. The module disconnect switch consists of a high current solid state contactor (power switch), a current sensor, and a microprocessor control/monitor circuit. It has a over current shutdown rating of 275 amps with a surge rating of 800 amps, and provides automatic fault shutdown for over current, high temperature and loss of ground conditions. Three models are available: SSC42-275, SSC42A-275 and SSC42B-275. The model variations are described in this document.

Five control inputs allow a variety of different application configurations to be offered, including three time delayed power shut-off modes. Input A allows control of the power switch from a +12 Vdc control switch without a timed shut-off mode. Input B allows control from a +12 Vdc input, and includes an adjustable off-delay power shut-off (module power is shut off after the time delay has expired). The time delay period can be set by the user via a potentiometer (screwdriver adjustment), and has a range of 0 to 20 minutes (0 - 10 seconds on SSC42B-275). By setting the adjustment to zero you can use Input B for a non-timed shutoff control. Input C is identical in function to Input B but is activated with a ground signal. Note that on Model SSC42A-275, Input B and Input C triggers the power switch to turn on and the shut off timer is started immediately so that the power switch will be on for only the time period. Input D allows mode control from one, two or three momentary ground signal pulses, providing a power switch turn-on for 5, 10 or 15 minutes, respectively. Input E allows for a momentary ground input that will cancel (reset to zero) all timer shut-off modes.

An amber LED indicator is provided to display the power switch status. It will be illuminated anytime the power switch is on, and it will flash to indicate if the power switch is on and in a timed shut-off mode (timer running). The LED will flash at a fast rate to indicate a fault shut down condition. A single turn potentiometer is provided to adjust the shut off timer.

Two 3/8 - 16 threaded studs with brass contact pads are provided for the DC power terminations. Optional terminal cover boots are available that fit over the power terminals, and are secured by a detent groove in the contact pad. These terminal boots are flexible PVC (UL94-V2 rated) and offer additional protection from the environment, as well as from accidental shorting. The five control inputs are 0.250 inch male Faston blade terminals. The module is sealed to protect from the environment. Its four mounting hole pads provide the required connection to ground.

2. System Diagram

InPower Solid State Module Power Disconnect

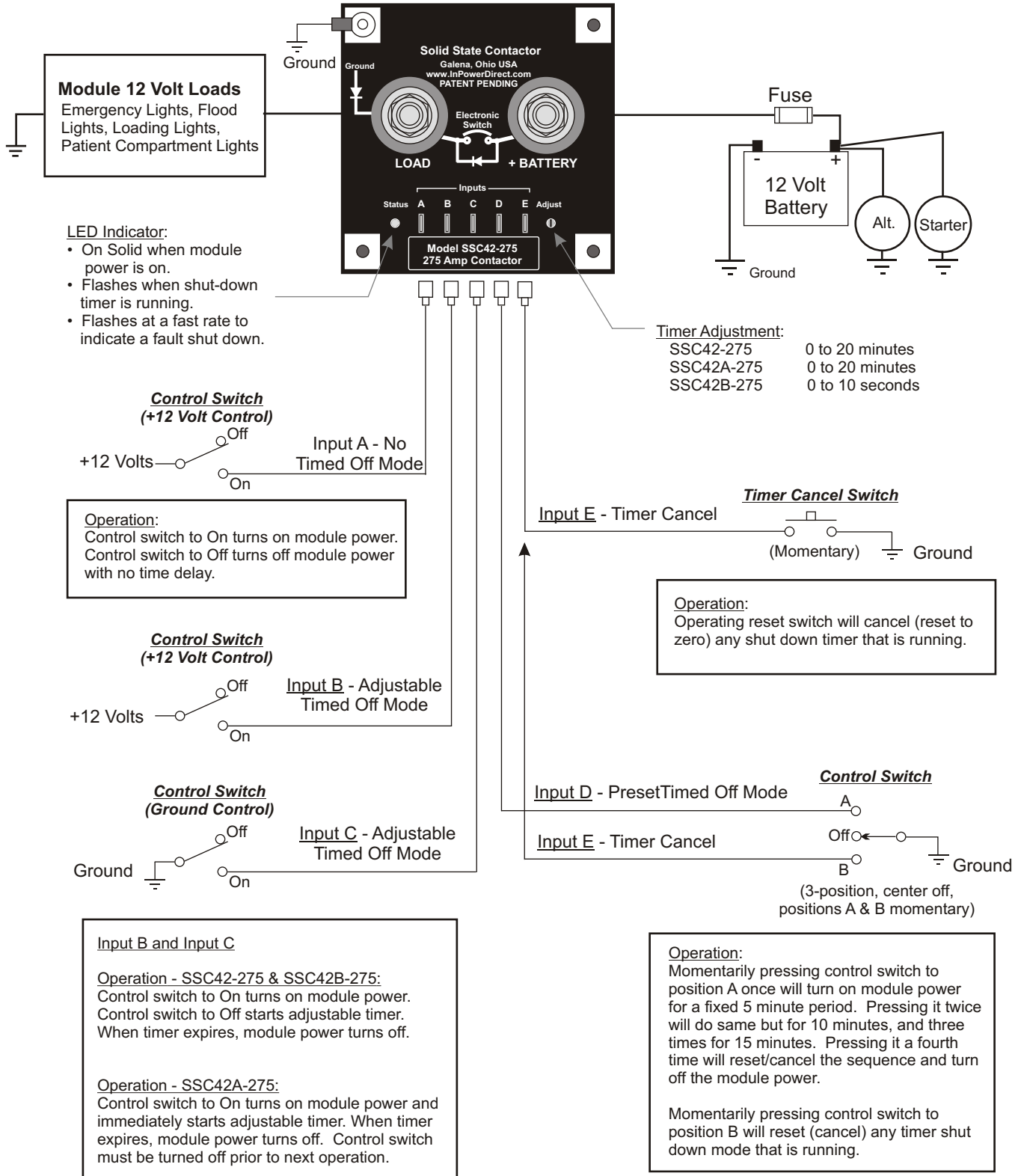

3. System Operation

3.1 Electronic Power Switch

The SSC42-275 module power disconnect switch contains a 100% electronic power switch that when activated, connects the LOAD terminal to the +BATTERY terminal, thereby delivering battery power to the module's 12 volt dc loads. The power switch is highly efficient and has a very low on-resistance. The benefit of this is a very low voltage drop and low internal heat dissipation. As many dc loads are inductive, the power switch contains an internal clamping diode between its LOAD terminal and ground. This will suppress negative inductive voltage spikes when the power switch is turned off. Note that it is very important that the unit is properly grounded to allow the clamping diode to work effectively.

The power switch monitors the amount of current passing through it and if this current exceeds specification the power switch will turn off and stay latched off until reset. The current trip point will activate if the 275 amps limit is exceeded for 750 milliseconds. Recovering from a latched shutdown condition requires clearing the overload condition, then either removing battery power from the +BATTERY terminal or cycling Input A, Input B or Input C to On, then Off.

3.2 Control Inputs

The SSC42-275 module power disconnect switch utilizes five control inputs to perform various functions. A key feature is its off-delay timed power switch shut-off modes. The off-delay shut-off can be an adjustable 0-20 minutes timer, or multiple fixed five minute shut down time intervals. If the unit is in any of the timed shut-down modes (timer running) the timer can be immediately cancelled (reset) by the activation of the Input E Timer Cancel input.

Inputs A and B contain a pull down resistor to ground and must be activated by supplying a positive dc voltage, such as a contact closure to +12 volts. Inputs C, D and E contain pull up resistors to +12 volts and are activated by a contact closure to ground.

Input A - Activating this input (+ 12 volts) will turn the power switch on. Removing the input turns the power switch off with no time delay.

Input B -

Models SSC42-275 and SSC42B-275: Activating this input (+12 volts) will turn the power switch on. When the input is removed a timer is started. When the timer expires the power switch will turn off. The timer is adjustable by a single turn potentiometer that is located on the top of the module. The timer's range is 0 to 20 minutes on SSC42-275 and 0 to 10 seconds on SSC42B-275.

Model SSC42A-275: Activating this input (+12V) turns the power switch on and immediately starts the timer. When the timer expires the power switch is shut off.

Note that this input can be activated from a 2-position switch such as the vehicle's ignition switch or momentary (push button) switch.

Input C - This input operation is identical to Input B except that it is activated by a ground signal.

Timer Adjustment - The adjustable timer is a single turn potentiometer located on the top of the module. You can adjust the timer by estimating its position as it is rotated about 250 degrees, as this equates to zero to 20 minutes. If you desire a more accurate setting, first turn the adjustment to its maximum time (full clockwise). Next activate the power switch by either Input B or Input C. When you de-activate the input start measuring time. When desired time has elapsed turn the timer adjustment down (counter clockwise) until the power switch turns off.

Input D - This input is activated by a momentary switch closure to ground. When activated by a pulse to ground the power switch is turned on for a fixed period of time. The time period is in multiples of five minutes, and is determined by how many input pulses are received (one, two or three). If one pulse is received the power switch turns on and a fixed five minute timer is started. When the five minute period is up the power switch is turned off. If two pulses are received the time period will be 10 minutes. If three pulses are received the time period will be 15 minutes. If a fourth pulse is received the timer will cancel and the power switch will immediately shut off.

3. System Operation (Continued)

Input E - This input is activated by a momentary switch closure to ground. When activated, any timer that is running will be cancelled (reset) and the power switch will be turned off. Note that this applies to Inputs B, C and D.

LED Status Indicator - The yellow LED indicator is located on the top of the module. The LED is on steady to indicate that the power switch is in a maintained on state. The LED will flash at a slow rate when a shutdown timer is running, indicating that the power switch will shut off when the timer expires. If a fault shut down has occurred the LED will flash at a fast rate.

Fault Shutdowns - The following conditions will cause the power switch to shut off and stay latched in the shut off state until reset.

1. Over Current - The power switch has sensed a current of greater than 275 amps for longer than 750 milliseconds.
2. Over temperature - The internal sensor has determined the case temperature to be greater than 85° C (185° F). This could be a result of the combination of internal heat generated from the current being handled and from the temperature of the mounting surface.
3. Loss of ground - If the ground connection is disconnected the power switch will turn off.

Resetting Fault Shutdowns

Resetting and unlatching a fault shutdown is accomplished by removing the source of the fault condition, then one of the following:

- Disconnect and reconnect the battery cable from the +BATTERY terminal, or
- Cycle Input A to On, then Off, or
- Cycle Input B to On, then Off, or
- Cycle Input C to On, then Off.

4. Specifications

| | |
|-----------------------------------|---|
| Under Voltage Rating: | +7.5 Vdc |
| Current Rating: | |
| Current Trip Rating: | 275 amps (750 milliseconds) |
| Surge Current Rating: | 800 amps |
| On-resistance at maximum current: | 660 micro ohms |
| Turn-On Delay: | 10 milliseconds |
| Turn-Off Delay: | 10 milliseconds plus off-delay timer |
| Control Input: | |
| Connector Type: | 0.250 inch male Faston blade terminal (5 total) |
| Control Voltage: | |
| Input A: | >2.6 Vdc to activate |
| Input B: | >2.6 Vdc to activate |
| Input C: | <2.1 Vdc to activate |
| Input D: | <2.1 Vdc to activate |
| Input E: | <2.1 Vdc to activate |
| Weight: | 0.30 lbs (0.136 kg) |
| Dimensions: | 4.15 x 4.15 x 1.50 inches |
| Power Terminals: | Two (2) 3/8 - 16 phosphor bronze threaded studs with zinc plated locking nuts. |
| Mounting Surface: | For optimal performance a metal mounting surface should be provided such as a 1/8 x 16 inch x 16 inch aluminum plate. |
| Terminal Boot Covers: | Order terminal boots to match cable size (not supplied with product). InPower model TM28-2 for 8 to 2 gauge cable, TB28-3 for 2 to 2/0 gauge cable. |

5. Mechanical Drawing

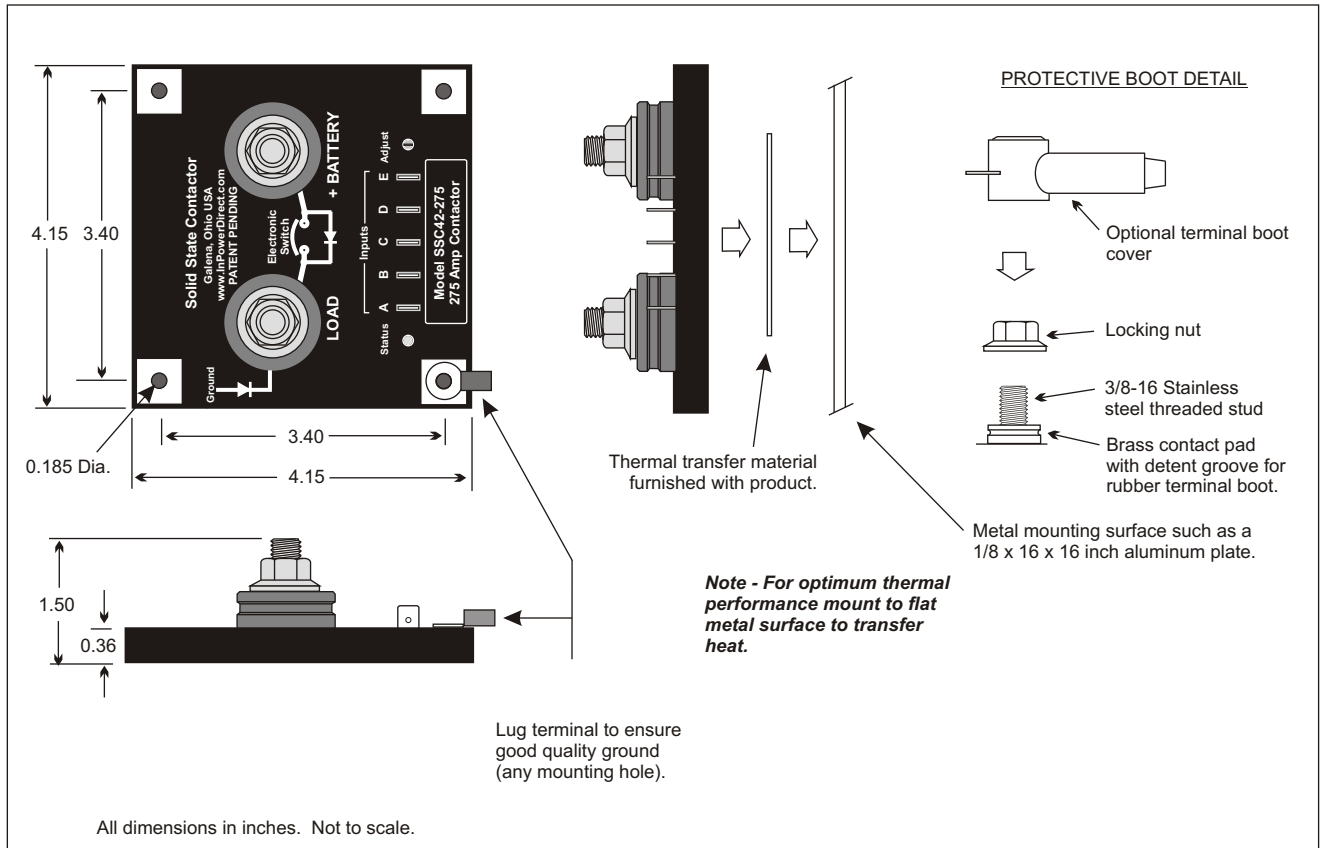

6. Installation Procedure

6.1 Introduction

This section provides instructions for installing the InPower Model SSC42-275 Ambulance Module Power Disconnect Switch ("disconnect switch"). It is important that you follow these instructions carefully and contact InPower if you need assistance or more information. You can reach InPower at:

InPower LLC
Customer Support
740-548-0965

6.2 Safety Precautions

This product requires the installer to be trained to install and work on vehicle electrical systems. We recommend that all wiring meet the SAE and applicable vehicle manufacturer's wiring specifications. Inspect the product and all other components for damage before starting the installation. Do not perform the installation if any problems exist.

Make sure that the vehicle battery power is disconnected during installation of the disconnect switch. Reconnect the battery when the system installation is complete. Wear appropriate safety equipment, such as protective eyeglasses, face shield and clothing when installing equipment and handling the battery. Be careful when working near a battery. Make sure that the area is well ventilated and that there are no flames near the battery. Never lay objects on the battery that can short the terminals together. If battery acid gets in your eyes, immediately seek first aid. If acid gets on your skin, immediately wash it off with soap and water.

6. Installation Procedure (Cont'd)

6.3 Mounting Location

First determine where the disconnect switch will be mounted. Take into consideration the large power cables that must connect the disconnect switch to the battery positive, as well as the power cables from the disconnect switch to the module 12 volt loads. Note that a fuse is necessary at the battery end of the cable running between the battery and the battery terminal on the disconnect switch. Although the disconnect switch is sealed we do not recommend installing it in a location that is exposed to the outside (severe) environment. It is necessary to provide a metal mounting surface that will absorb the heat that is produced by the disconnect switch. The metal surface must be flat so that the disconnect switch will not be distorted when bolted down. We recommend an aluminum plate 1/8" x 16" x 16" or larger. If this size and type of mounting surface cannot be provided it will be necessary to derate the maximum current rating of the power switch. **The disconnect switch should not be located in the engine compartment or any location near the engine's heat.** To facilitate heat transfer a square piece of thermal transfer material is supplied with each disconnect switch. Remove the clear plastic protective covering and insert the heat transfer material between the disconnect switch and the mounting surface. Secure the disconnect switch to the mounting surface using four screws. If the mounting surface is a good quality ground (low resistance to the battery negative terminal) the mounting screws will provide a good ground connection. **If the mounting surface is not a good ground, or you are not sure, you must install a ground wire with a ring terminal under one of the mounting screws. This ground wire must be a low resistance to battery negative.**

6.4 Connect the Power Cables

First, make sure that the battery is disconnected. Prepare the cable to the battery using a suitable size cable for the current required and install a crimped lug terminal on the end. Be sure that you have installed a protection device (fuse, fuse link or circuit breaker) at the battery end of the cable. If required, install a rubber terminal boot over the cable and lug, then install the cable as shown in the diagram on page 7. Torque the nut to the value shown in the diagram. Slide the boot over the lug and into the detent groove on the power terminal. Prepare the cable to the loads and install the cable as you did with the battery cable.

6.5 Control Circuit

The control circuit wiring will consist of one or more remote switches that will wire to the five disconnect switch control inputs that are labeled Input A through Input E. Inputs A and B must be activated by a positive dc voltage (>2.6 Vdc). We recommend that the remote switches are connected to a +12 volt source. Input C, D and E must be activated by a ground signal so these remote switches must be wired to a good ground (low resistance to battery negative). Refer to the diagram on page 2 for further details and functionality. Prepare the required control wires by crimping female 0.25 inch Faston blade terminals on the wires and attach them to the disconnect switch. Be sure to install a strain relief on the control wires near the disconnect switch.

6. Installation Procedure (Cont'd)

Installation Diagram

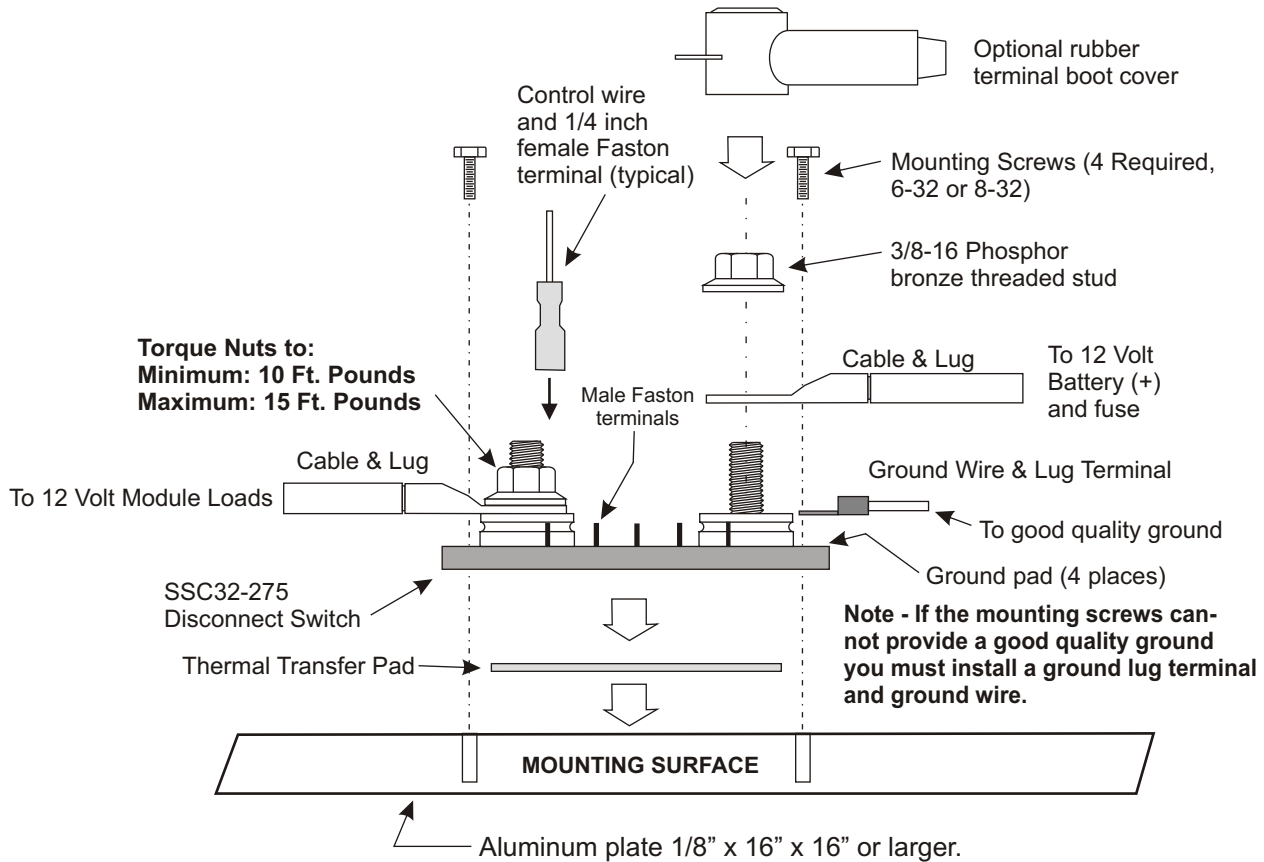

IMPORTANT NOTE -

The mounting surface provides a means to remove heat that is generated by the SSC42-275 disconnect switch. If this surface is a poor conductor of heat the disconnect switch will have a lower current rating than if the surface is a good conductor of heat and has a sufficiently large area.