

OWNERS MANUAL

InPower Model ITM123A-F Platform Lift Interlock 2009-2010 Ford F-Series Vehicles

Contents

1. Introduction	1
2. Product Description	1
3. Installation Procedures	1
4. System Circuit Diagrams	2
5. Wiring Instructions	4
6. Interlock System Operation.....	6
7. System Troubleshooting	6
8. Mechanical Drawings.....	7
9. Reference Information	7

1. Introduction

This product is intended for installation in 2009-2010 Ford F-Series chassis with FMVSS compliant, public use platform lifts manufactured by The Braun Corporation, Ricon Corporation or Maxon Mobility. If another type of lift is to be used, contact the lift manufacturer to determine its compatibility.

This interlock system is designed to meet the requirements of FMVSS 403/404 and therefore must be installed in accordance with the lift manufacturer's instructions. The installer must be trained and skilled in installing FMVSS compliant lift systems. The installation must also comply with SAE (Society of Automotive Engineers) and Ford Motor Company electrical wiring procedures.

2. Product Description

The ITM123A-F interlock system consists of a control module, remote driver's LED display, and chassis interface wiring harness. The control module is a solid state, non-microprocessor-based control device. It contains two connectors for interfacing to the remote LED display and chassis interface wiring harness. The chassis interface harness contains two "plug and play" tee-cables that connect to the parking brake switch and shift lock solenoid (located under the dash), as well as blunt-cut wires for interfacing to the platform lift system, door switches, and +12 volt power source. The driver's LED status display contains indicators for Park, Lift Enabled, Shifter Locked, Park Brake Set and Door Ajar. The door ajar indicator is a large two inch indicator that flashes if the lift door, driver's door or passenger door is open or ajar.

3. Installation Procedures

3.1 Safety Precautions



WARNING

This interlock product has been designed and manufactured to meet the intended application requirements and specifications. Any modifications to the product or to the installation procedure can be dangerous and will void InPower's warranty.

- Read and understand the instructions in this manual and other manuals before starting the installation.
- Make sure that the vehicle battery power is disconnected during installation of the Interlock and lift systems.
- Reconnect the battery when the system installation is complete.
- Wear appropriate safety equipment, such as protective eyeglasses, face shield and clothing when installing equipment and handling the battery.
- Be careful when working near a battery. Make sure that the area is well ventilated and that there are no flames near the battery. Never lay objects on the battery that can short the terminals together. If battery acid gets in your eyes, immediately seek first aid. If acid gets on your skin, immediately wash it off with soap and water.

3.2 Getting Started

This manual provides instructions for installing the InPower Model ITM123A-F Interlock System in a 2009-2010 Ford F-Series chassis with a FMVSS compliant, public use (commercial) platform lift. It is important that you follow these instructions carefully and contact InPower if you need assistance or more information. Note that product technical documents are available on InPower's web site.

! WARNING

Before installing and operating this interlock system, read and understand the lift manufacturer's safety, operating and installation instructions.

This interlock system installation requires additional parts and materials that are not supplied with the interlock product (See Section 9.2). Identify all required parts before starting the installation and ensure that these items are the correct type and quality.

Inspect the interlock product and all other components for damage before starting the installation. Do not perform the installation if any problems exist.

Determine the type of interlock interface required for the platform lift. This interlock system provides a +12 volt @ 10 amps *Lift Enable* output to allow the platform lift to be operated. If the lift system is not compatible with this interface signal you must take the necessary actions to adapt the lift system interface to the interlock system's interface. Refer to the lift manufacturer's installation instructions for further details.

The recommended mounting location for the ITM123A-F interlock module is under the dash, to the left of the steering column due to the proximity of the wiring connections. **The unit must not be located in the engine compartment or any location that is not protected from the environment.**

4. System Circuit Diagrams

The following pages show the individual circuits that need to be wired. The following section, 5. *Wiring Instructions*, describes how to wire these circuits.

Interlock System Layout

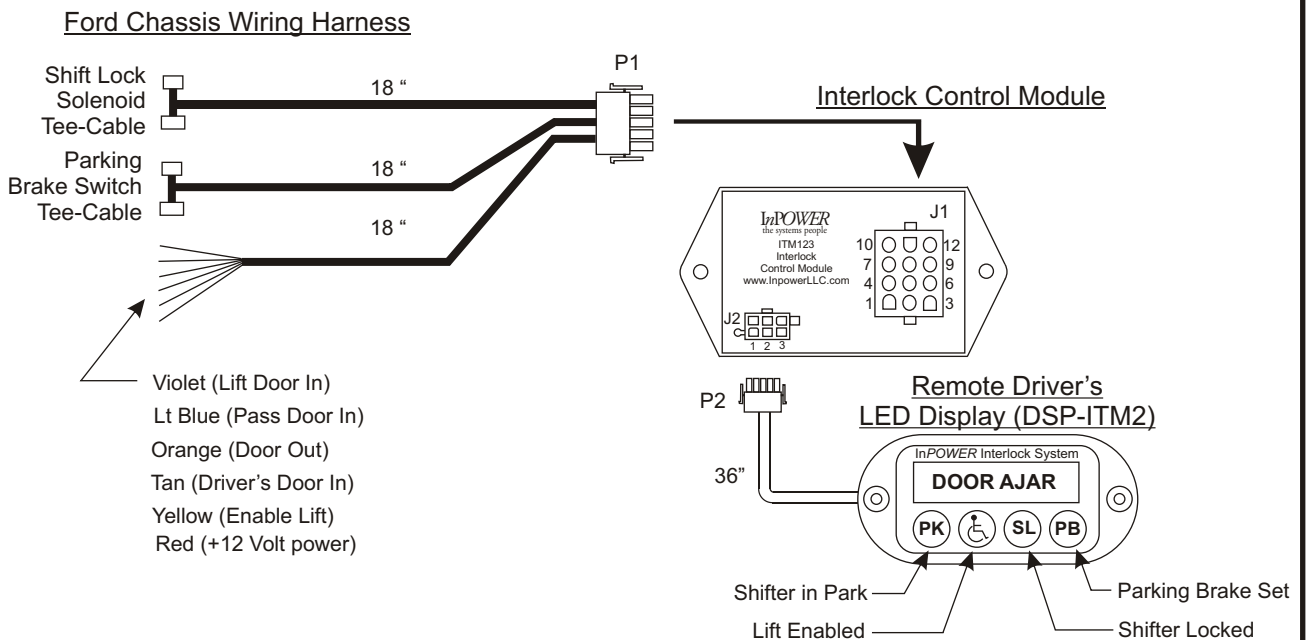

4. System Circuit Diagrams (Cont'd)

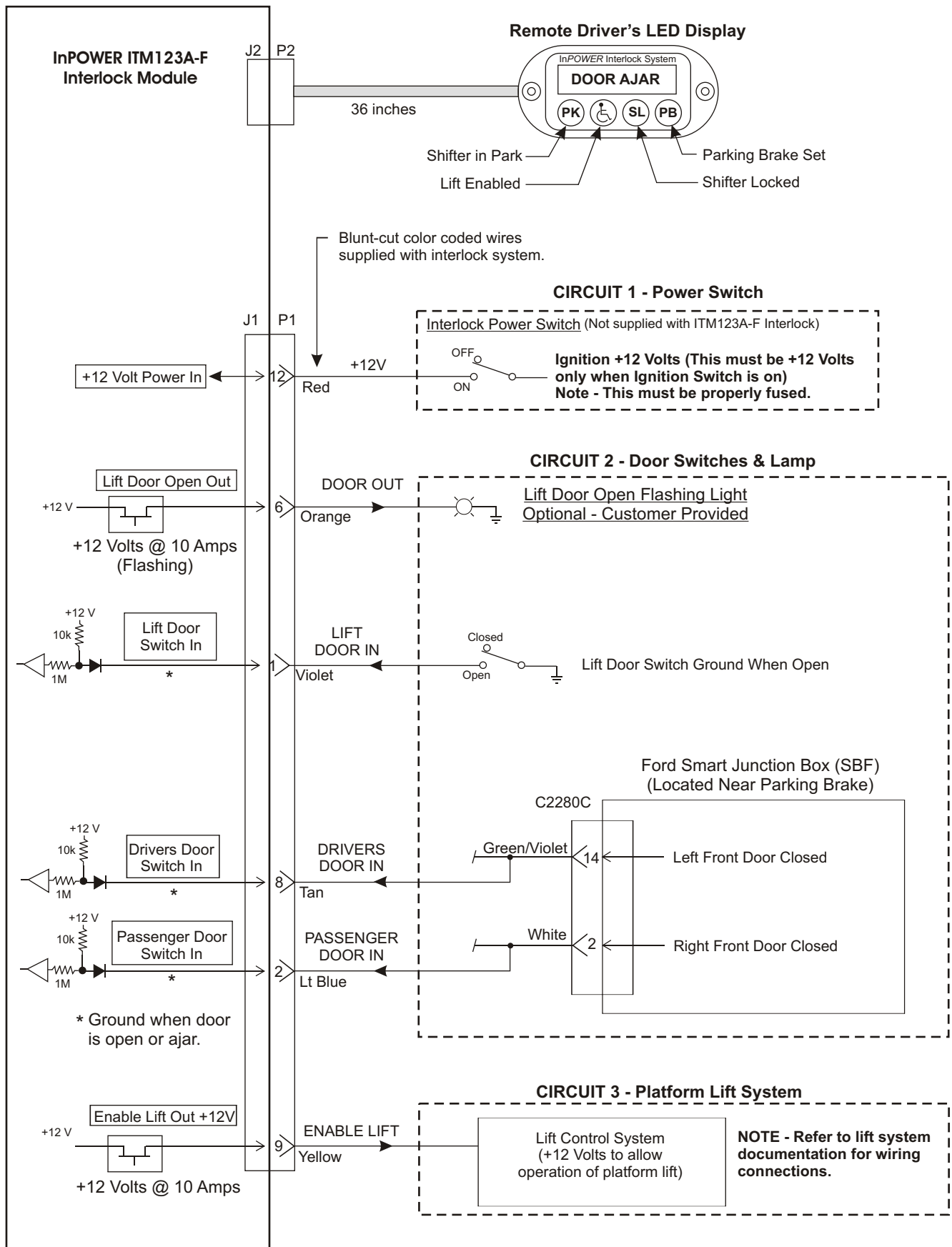

4. System Circuit Diagrams (Cont'd)

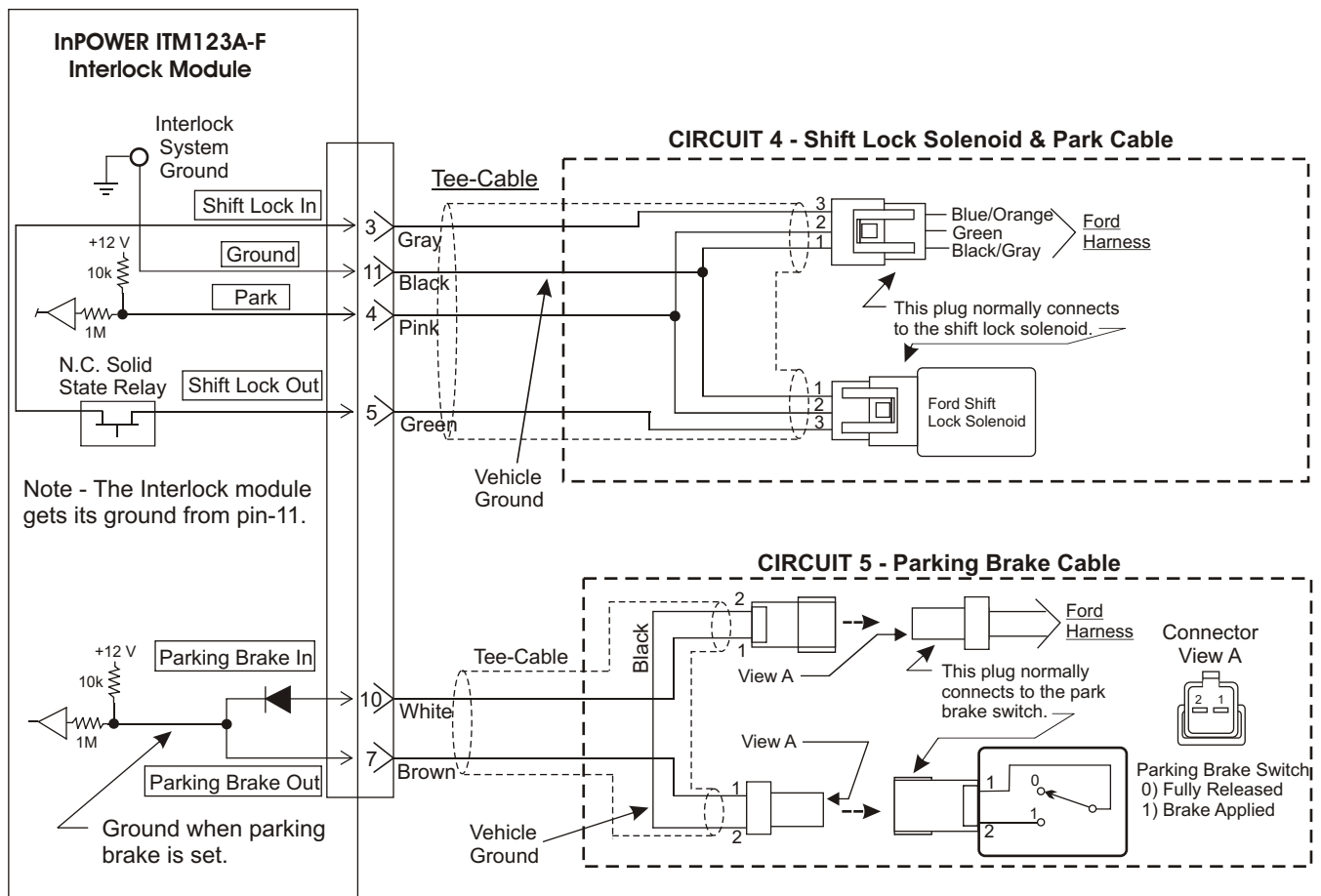

5. Wiring Instructions

⚠ WARNING

Make sure that the vehicle battery power is disconnected during installation of the Interlock and lift system. Reconnect the battery when the system installation is complete.

Circuit 1 Wiring (Interlock System Power Switch)

The installer must supply a two-position On-Off Interlock power switch capable of handling the combined current of the Lift Enable and Door Open/Ajar outputs. This switch may be mounted on the dash at a convenient location. NOTE - An alternative method is to wire the interlock module power input directly to a +12 volt fused power source that is powered by the Ignition Switch, and delete the Interlock Power Switch.

1. Mount the Interlock Power Switch.
2. Wire the "common" side of the Power On/Off switch to a properly fused +12 volt ignition switch source (**powered when the ignition switch is On**). Refer to the Ford documentation for location of customer access ignition circuits.
3. Wire the "On" position side of the switch to the Red harness wire that goes to pin 12 on the interlock module.
4. When complete, you should have +12 volt fused power on the interlock module pin 12 when the ignition switch is On and the Interlock Power Switch is On.

NOTE - Do not power the interlock system directly from the Battery or any power source that is not fused and turned off with the ignition switch.

5. Wiring Instructions (Continued)

Circuit 2 (Lift Door Switch, Driver's Door Switch and Passenger Door Switch)

The interlock system contains three inputs for vehicle door switches. These switches are activated when a door is ajar or open, and when activated, apply a ground to the interlock system inputs. These signals are available at the Ford *Smart Junction Box* located near the Parking Brake as shown on Circuit #2 diagram. Note that the lift door switch signal input is used for both the interlock system's logic and to operate the Door Ajar indicator's flashing indicators. The driver's door switch signal and the passenger door switch signal are used only to activate the Door Ajar flashing indicator on the remote display, as well as the Door Out flashing 12 volt output that can be used to operate a remote indicator light. Wire the three switches signal as shown in the Circuit #2 diagram. Ensure that these switches signals apply a ground to the interlock input when the door is open/ajar. Refer to Ford wiring diagrams for details door switches signals.

Circuit 3 Wiring (Platform Lift)

1. Review the platform lift installation manual and determine how to wire the ITM123A-F interlock system to the following lift interface connections:

Enable Lift - This is a +12 volt **OUTPUT** from the interlock system and a **INPUT** to the lift system. When at +12 volts, the platform lift can be operated. Install a wire from the platform lift's *Enable Lift* input to the ITM123A-F yellow wire to pin 9 on the interlock module.

Note - The ITM123A-F will supply a +12 volt @ 10 amp output to allow operation of the lift. Verify that this is the correct polarity for the platform lift.

The following diagrams show the wiring interface of typical platform lift systems. **Be sure to verify the exact wiring interface for the lift system that you have.**

Braun FMVSS Platform Lifts

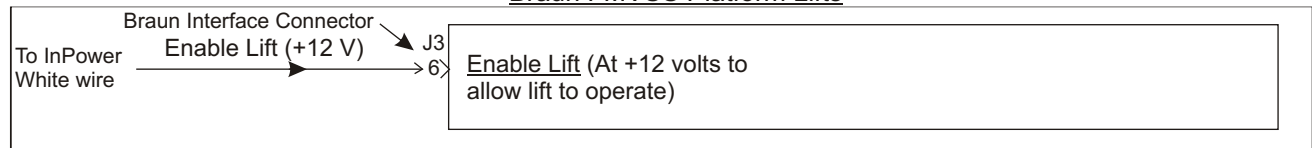

Ricon Series S Platform Lifts

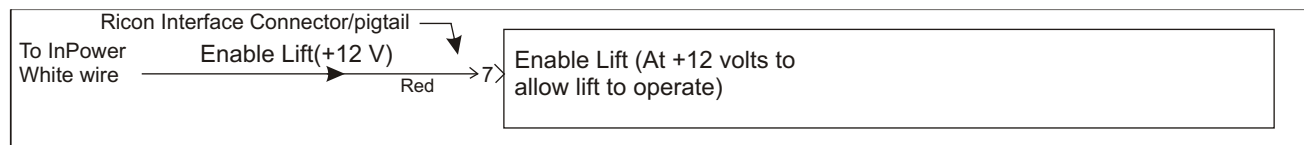

Maxon Platform Lifts

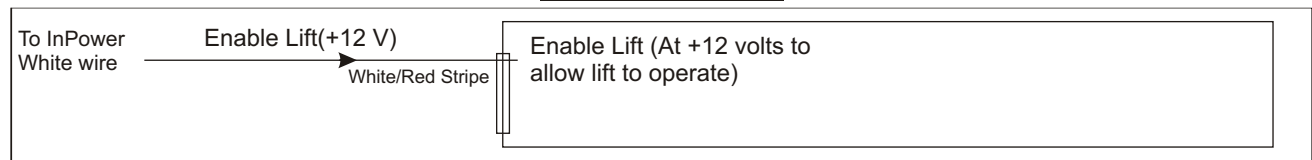

Circuit 4 Wiring (Shift Lock Solenoid Cable)

1. Locate the shift lock solenoid that is on the top left of the steering column behind the dash panel. It has a three-wire harness plugged into it.
2. Remove the harness plug from the solenoid assembly.
3. Install the tee-cable supplied with the interlock between the solenoid connector and the harness plug that you removed from the solenoid. When complete, the interlock tee-cable will be connected to the Ford harness plug and the shift lock solenoid as shown in Circuit #4 diagram.

5. Wiring Instructions (Continued)

Circuit 5 Wiring (Parking Brake Switch Cable)

1. Locate the Parking Brake Switch connector C2015 that is near the parking brake pedal assembly. It has A two-wire harness plugged into it.
2. Remove the harness plug from the switch connector.
3. Install the tee-cable supplied with the interlock wiring harness between the parking brake switch connector and the harness plug that you removed from the parking brake switch connector.
4. When complete, the interlock tee-connector will be connected to the Ford harness plug and to the parking brake switch connector as shown in Circuit # 5 diagram.

Remote Driver's LED Display

NOTE - Consult Ford documentation before drilling to verify the location of all critical components and harnesses.

The LED display includes a 36 inch cable that plugs into the connector on the rear center of the display. Mount the display in a suitable location on the dash (usually to the right of the steering wheel). To mount the display drill a hole in the dash so that the cable can be routed through and behind the dash. Attach the display with the to mounting screws provided, route the cable to the interlock control module, and insert the cable plug into connector J2.

6. Interlock System Operation

The interlock system is powered from the Interlock Power Switch and the Ignition Switch when they are both in the On position. The following is the interlock system sequence of operation:

- Step 1 - Ignition switch on and engine running.
- Step 2 - Press service brake and place shifter in Park.
- Step 3 - Set parking brake.
- Step 4 - Open lift door.
 - The Door Ajar indicator will activate
 - Shift Lock will activate
 - Lift Enable will activate allowing operation of platform lift.
- Step 5 - The platform lift may now be operated (Refer to the platform lift operating instructions).
Note - During the Lift Enable sequence, if the parking brake is released the Lift Enable will be deactivated, preventing lift operation.
- Step 6 - When the lift cycle is completed return the lift to its fully stowed position.
- Step 7 - Close the lift door.
- Step 8 - Release parking brake. When released, the shift lock will be automatically released.
- Step 9 - The cycle is now complete and the vehicle can be taken out of Park and driven.

Notes:

1. The Door Ajar indicator on the driver's LED display will flash when the lift door, driver's door or passenger door is open/ajar (not fully closed).
3. The lift door switch is used by the interlock systems logic as well as to activate the Door Ajar indicator. The driver's door and passenger door switches are only used to activate the Door Ajar indicator.

7. System Troubleshooting

If there is a problem with system operation, there is a very high probability that the control module has: A) either lost its ground or +12 volt power source, or B) that one or more of its inputs are not being actuated by the remote switches (e.g., Lift Door Switch). Most troubles are related to wiring problems, or switches either failing or becoming out of adjustment.

7. System Troubleshooting (Continued)

Troubleshooting Procedure:

- Step 1 - Determine if the control module is powered. If the LEDs on the Remote Display Module are illuminated you have power. If none are illuminated, check the +12 volt supply on +12V terminal with a voltmeter. Also check that the module is getting a good ground on pin 11 of connector J1
- Step 2 - If the ground and power are correct, first reset the interlock system by turning off its power. Then, step through the operating sequence as described in Section 6. *Interlock System Operation*, and note the status of the LED indicators on the Remote Display Module. Pay particular attention to The lift door switch input.

8. Mechanical Drawing

Model ITM123A-F Control Module

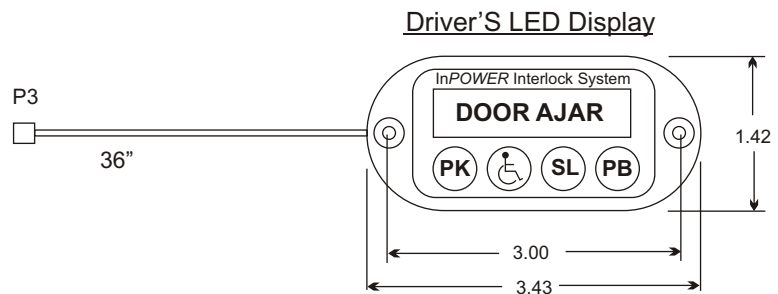
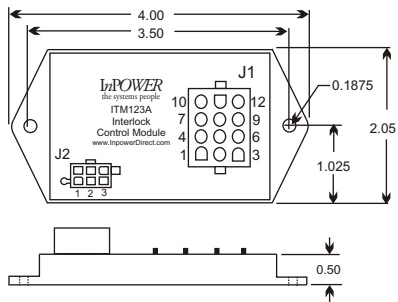

All dimensions in inches. Not to scale.

9. Reference Information

9.1 Company Contacts

Ford Motor Company

Truck Body Builder Advisory Service
Product Development Center
MD 410
PO Box 2053
Dearborn, MI 48121-2053
1-877-840-4338
www.fleet.ford.com/truckbbas/index.htm
bbasqa@ford.com

The Braun Corporation

631 West 11th Street
Winamac, IN 46966
(574) 946-6153
(800) 946-6158
www.braunlift.com

Ricon Corporation

7900 Nelson Road
Panorama City, CA 91402
(818) 267-3038
(800) 322-2884
www.riconcorp.com

Maxon Lift Corp.

11921 Slauson Avenue
Sante Fe Springs, CA 90670
(562) 464-0099
(800) 227-4116
www.maxonlift.com

9.2 Required Parts Not Supplied with ITM123A-F Interlock System

1. Power switch and fuse. See page 3, Circuit 1.
2. Lift door switch, driver's door switch and passenger door switch. (See page 3, Circuit #3)
3. Optional door open lamps.
4. Miscellaneous wire, mounting hardware, wire tie wraps, wire loom.