

Electronic Throttle Module



Vehicle Make: Ford

Model Year/Engine:

2005 - 2006 6.0 L Power Stroke V8 Diesel

2005 - 2006 6.8 L Triton V10 Gas

2005 - 2006 5.4 L Triton V18 Gas

Chassis: F-Series Trucks, E-Series Vans*,
Excursion SUV*

* Only if equipped with Ford SEIC

Applications

- Ford Triton Gas and Power Stroke Diesel Truck and Van Engines
- Pumper Trucks
- Aerial Trucks
- Power Take-Off (PTO) Systems
- Emergency Vehicles
- Service and Rescue Trucks
- Hydraulic Systems
- Air Compressors
- Power Inverter Systems

Key Features

- Supports 2005-2006 Ford diesel and gas engines with automatic or manual transmissions
- Three user-adjustable speed presets with priority control
- Variable speed input for remote control of fast idle speed
- Diagnostic LEDs provide system and chassis sensors status
- Works in conjunction with Ford's built-in Stationary Elevated Idle Control (SEIC)
- Consistent speed ramp rate control between speed presets

The ETM50 Electronic Throttle Controller provides four modes of engine rpm control for Ford trucks, vans, and buses. Four selectable modes of fast engine idle operation include three preset fixed speeds, and a variable speed control via an external potentiometer. Ten LED indicators are provided to display the selected operating mode, system status, and error conditions. The ETM50 controller module is compact, measuring only 2 x 4 inches. Wiring terminations utilize 0.25 inch Faston (blade) terminals. Its circuitry is encapsulated for maximum environmental protection.

Installation is simplified with a wiring harness that plugs into the vehicle's engine data bus, eliminating the need to wire into chassis sensors or the accelerator pedal module. The ETM50 module mounts under the dash and is supplied with a three foot cable that plugs into the vehicle's OBDII Data Link Connector. Customer provided wiring is required to select the fast idle mode and to connect to the Ford SEIC harness (three blunt-cut wires).

System Diagram

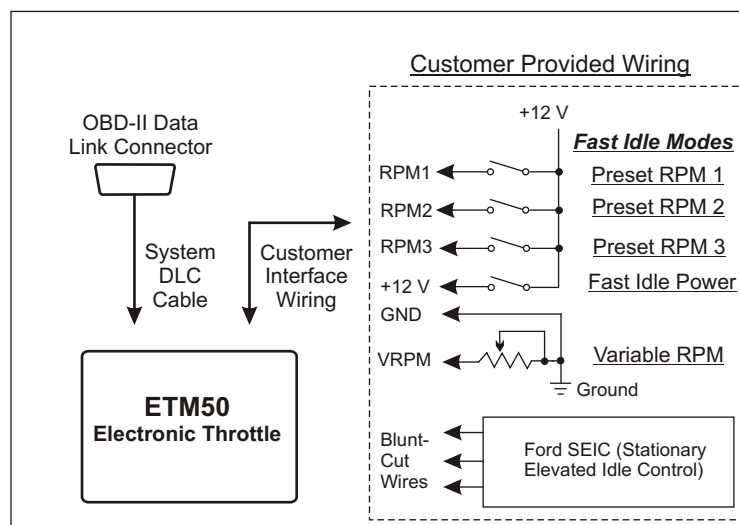

ETM50 Electronic Throttle Modules

Specifications

Modes of Operation

A. Preset RPM Modes

Function: Increases idle to a preset rpm
 Number of presets: Three
 Input identification: RPM1, RPM2 & RPM3 (RPM1 has highest priority, then RPM2, and RPM3 the lowest priority).
 Activation: Apply +12 V to input to select mode
 Range of calibration:
 Diesel Engine: 1200 to 2400 RPM
 Gas Engines: 900 to 2340 RPM
 Calibration method: Internal potentiometers (3)

B. Variable RPM Mode

Function: Varies rpm as a function of external resistance change
 Input identification: VRPM
 Adjustment: 10k Ohm potentiometer between input terminal and ground
 RPM range:
 Diesel Engines: 1200 to 2400 rpm
 Gas Engines: 900 to 2340 rpm

Power Requirements

Input Voltage: 8 to 16 volts dc (from Ignition Switch)
 Input Current: 30 milliamps

2005-06 Ford Engines Supported

6.0 Liter Power Stroke V8 Diesel
 6.8 Liter Triton V10 Gas
 5.4 Liter Triton V8 Gas

NOTES

1. Refer to Ford Body Builders Manual for application restrictions that may apply.
2. Certain chassis are not supported as they do not have the Ford SEIC feature.
3. For Charge Protect function refer to the SEIC documentation.

DIAGNOSTIC LED

LED	FUNCTION
1. BUS	<u>Solid</u> - Module ON and functioning. <u>Flashing</u> - Module ON, but a problem was detected.
2. GEAR	<u>Solid</u> - Transmission in PARK position. <u>Flashing</u> - Trans. not in PARK position.
3. PK BRK	<u>Solid</u> - Parking Brake set. <u>Flashing</u> - Parking Brake not set.
4. SR BRK	<u>Solid</u> - Service Brake not set <u>Flashing</u> - Service Brake actuated.
5. VSPD	<u>Solid</u> - No vehicle speed. <u>Flashing</u> - Vehicle speed sensor shows movement.
6. RPM1	<u>Solid</u> - At fast idle speed 1. <u>Flashing</u> - Can't go to fast idle 1 due to interlock.
7. RPM2	<u>Solid</u> - At fast idle speed 2. <u>Flashing</u> - Can't go to fast idle 2 due to interlock.
8. RPM3	<u>Solid</u> - At fast idle speed 3. <u>Flashing</u> - Can't go to fast idle 3 due to interlock.
9. VRPM	<u>Solid</u> - In Variable Speed control mode (> 0 Ohms). <u>Flashing</u> - Can't go to fast idle speed due to interlock.
10. APDL	<u>Solid</u> - Accelerator Pedal at rest. <u>Flashing</u> - Accelerator Pedal actuated.

Mechanical Drawing

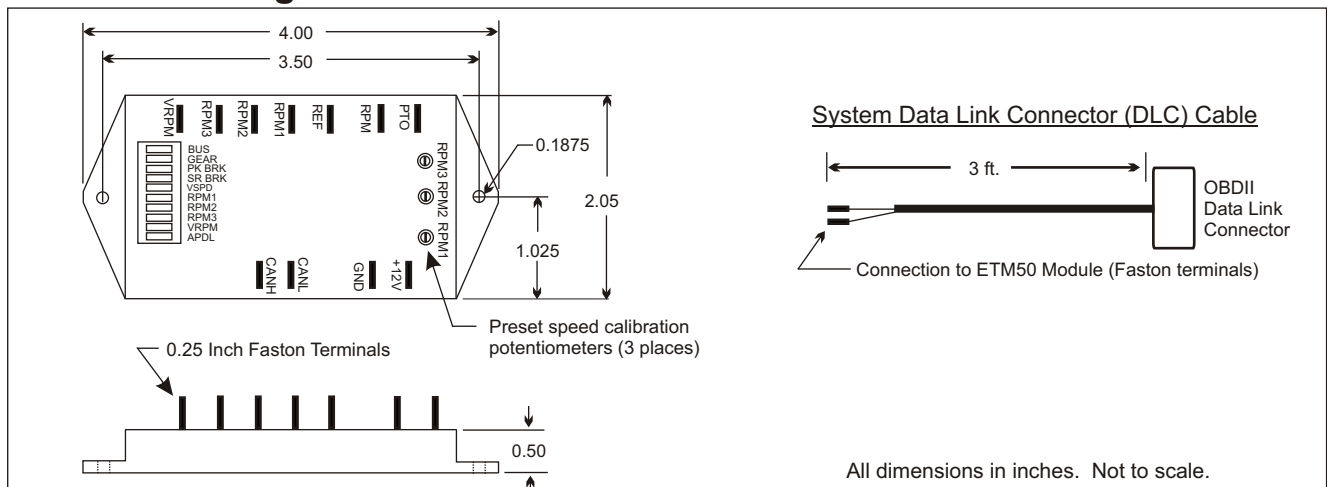

InPOWER LLC

3555 Africa Road
 Galena, Ohio 43021
 Tel 740-548-0965
 Fax 740-548-2302

www.InPowerDirect.com

Offered by:

PDS31B - 121305

© Copyright 2005 InPOWER LLC

Specifications subject to change without notice.