

GM Electronic Throttle Module



Applications

- Emergency Vehicles
- Work Trucks
- Transit & Shuttle Buses
- Pumper Trucks
- Service and Rescue Vehicles
- Hydraulic Systems
- Air Compressors
- Power Inverter Systems
- Warning Light Systems

Key Features

- Three user-adjustable speed presets with priority control
- *Charge Protect* automatic fast idle mode
- Engine Control Module programming for speed presets not required
- No Chevy/GMC options required
- Direct interface to engine data bus
- Hardwired parking brake switch input
- LED status and troubleshooting indicators

Fast Idle Speed Control for Chevy and GMC Trucks, Vans and Sport Utility Vehicles

Vehicle Compatibility

This electronic throttle is compatible with only certain GM vehicle configurations. Refer to *InPower GM Electronic Throttle Application Guide AB-20* to determine the electronic throttle model that matches your vehicle model year, chassis, engine and transmission.

The ETM67A Electronic Throttle Controller provides four modes of engine rpm control for certain Chevy & GMC trucks, vans, buses and sport utility vehicles equipped with gas or diesel engines and automatic transmissions.

Four available modes of fast engine idle operation include three preset fixed speeds and *Charge Protect*, which will automatically increase engine speed to maintain the battery charge. The three fixed speed preset modes are selected by applying +12 volts to the RPM1, RPM2 or RPM3 mode input terminals. The three fast idle presets can be individually adjusted by calibration potentiometers accessible on the top of the module. Ten LED indicators are provided to display the selected operating mode, system status, and error conditions.

The fast idle function includes interlock safeguards that must be satisfied before the engine speed can be increased. These enablers include: transmission in Park, parking brake set, engine running, vehicle stationary (no speed), foot off service brake, and foot off accelerator.

The ETM67A controller module is compact, measuring only 2 x 4 inches. Wiring terminations utilize 0.25 inch Faston (blade) terminals. The controller mounts under the dash and is supplied with a three foot cable that plugs into the vehicle's OBD-II Data Link Connector.

System Diagram

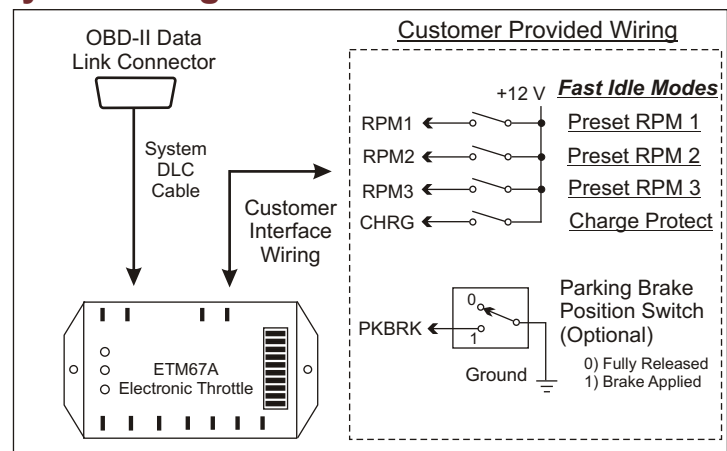

ETM67A Electronic Throttle Module

Specifications

Modes of Operation

Fast Idle Modes

A. Preset RPM Modes

Function:	Increases idle to a preset rpm
Number of presets:	Three
Input identification:	RPM1, RPM2 & RPM3
Activation:	Apply +12 V to input to select mode
Range of calibration:	650 to 1500 rpm (diesel) 650 to 2000 rpm (gas)
Calibration method:	Internal potentiometers (3)

B. Charge Protect Mode

Function:	Varies rpm to maintain battery charge
Input identification:	CHRG
Activation:	Apply +12 V to input to select mode
RPM range:	900 to 1700 rpm

Safety Interlocks

The following conditions must be met before the ETM67 controller will initiate a fast idle mode:

1. Engine running at idle speed below 1000 rpm
2. No vehicle speed (less than 3 MPH)
3. Automatic transmission in PARK
4. Service brake not depressed
5. Accelerator pedal not depressed
6. Parking brake set (hardwired input from switch)

Owner's Manual

For installation and operating instructions see InPower document OM-64.

Power Requirements

Input Voltage:	8 to 16 volts dc (from Ignition Switch)
Input Current:	30 milliamps

Parking Brake Input

The parking brake set interlock requires the installation of a wire from the parking brake switch to the PK BRK terminal on certain chassis. When a ground is applied to the terminal the parking brake set interlock is satisfied.

PTO Output

The PTO output is set (+12 volts @ 3 amps) when a mode input (RPM1, RPM2 or RPM3) is set, the safety enabler interlocks are satisfied, and the ETM67A module has entered the fast idle mode. If any interlock become unset the PTO output will turn off and the ETM67A module will release control of the engine rpm. The LED corresponding to the unset interlock will flash.

Mechanical Drawing

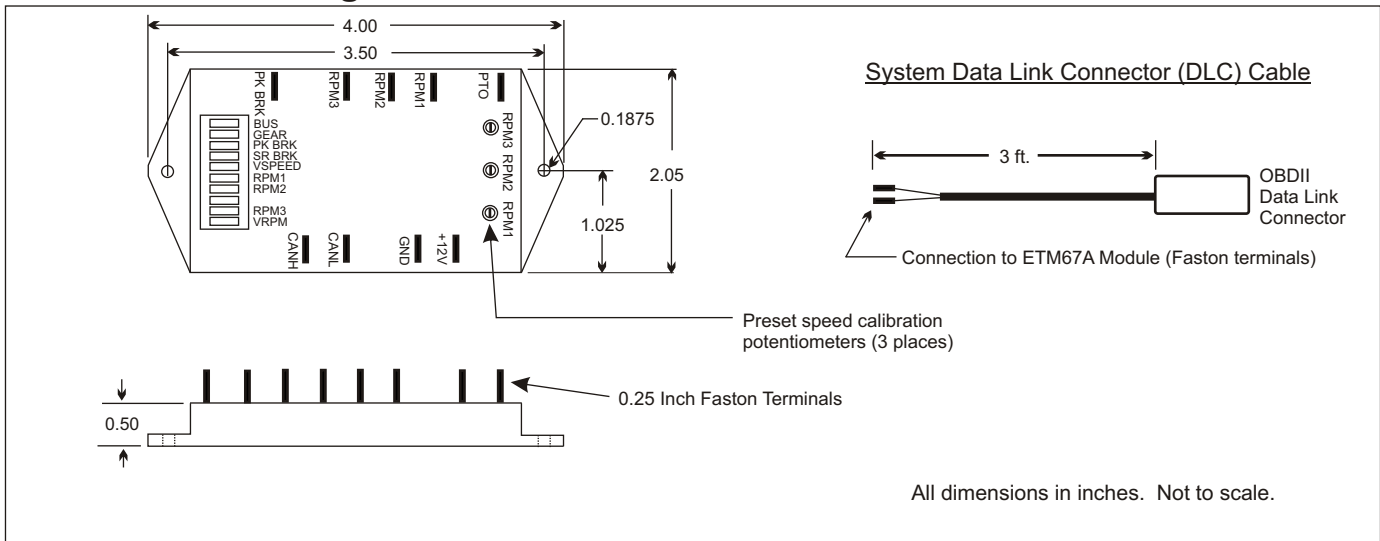

InPOWER LLC

3555 Africa Road
Galena, Ohio 43021
Tel 740-548-0965
Fax 740-548-2302

www.InPowerDirect.com

PDS-53B 012509

© Copyright 2009 InPOWER LLC

Specifications subject to change without notice.

Offered by: