



VCM-04.X

Time Delay Solid State Relay, Off-Delay

InPower's VCM Series *Vehicle Control Modules* are a set of "tools" for the designers of vehicle electrical control systems. These solid state modules are designed to withstand the environments typically found on trucks, emergency vehicles, buses, coaches and speciality vehicles, and are available in a variety of standard and custom configurations and functions.

Technical Description

The InPower VCM-04.X is a completely solid state adjustable off-delay timer relay with a single +12 volt @ 15 amp output. The module has two inputs, one actuated by a transition to +12 volts (Input A) and one actuated by a transition to ground (Input B). The two inputs operate as a logical "Exclusive OR" so that either input can cause the timer to operate.

When an input is applied the output will immediately be activated. When the input is removed, the timer will start and the output will remain activated. When the timer expires the output will deactivate. The time period is adjustable with a single turn potentiometer. Time ranges include: 0-10 seconds, 0-60 seconds, 0-3 minutes, 0-10 minutes, 0-60 minutes, and fixed 5 seconds.

The output will be activated when +12 volts is applied to Input A while Input B is open, or when ground is applied to Input B while Input A is open. When the applied input has cleared, and its counterpart input is also clear, the timer will start. When the timer has expired the output will be deactivated and the operation is complete. The output is rated at +12 volts @ 15 amps and provides over current and short circuit shut down protection.

Key Features

- 100% Solid State Construction
- Standard Automotive Relay Pin Format
- 12 Volt 15 Amp Solid State Output
- Compact Size with Panel-Mount Bracket
- Dual Inputs - Ground and +12 Volt
- Durable Metal Case

Ordering Guide

Model	Time Range	Description
VCM-04.10SA	0 - 10 Sec.	Solid state off-delay time delay relay with +12 volt @ 15 amp output and two inputs
VCM-04.60SA	0 - 60 Sec.	Solid state off-delay time delay relay with +12 volt @ 15 amp output and two inputs
VCM-04.03MA	0 - 3 Min.	Solid state off-delay time delay relay with +12 volt @ 15 amp output and two inputs
VCM-04.10MA	0 - 10 Min.	Solid state off-delay time delay relay with +12 volt @ 15 amp output and two inputs
VCM-04.60MA	0 - 60 Min.	Solid state off-delay time delay relay with +12 volt @ 15 amp output and two inputs
VCM-04.05SF	5 Sec. Fixed	Solid state off-delay time delay relay with +12 volt @ 15 amp output and two inputs
VCM-04.05MF	5 Min. Fixed	Solid state off-delay time delay relay with +12 volt @ 15 amp output and two inputs

Wiring Diagram

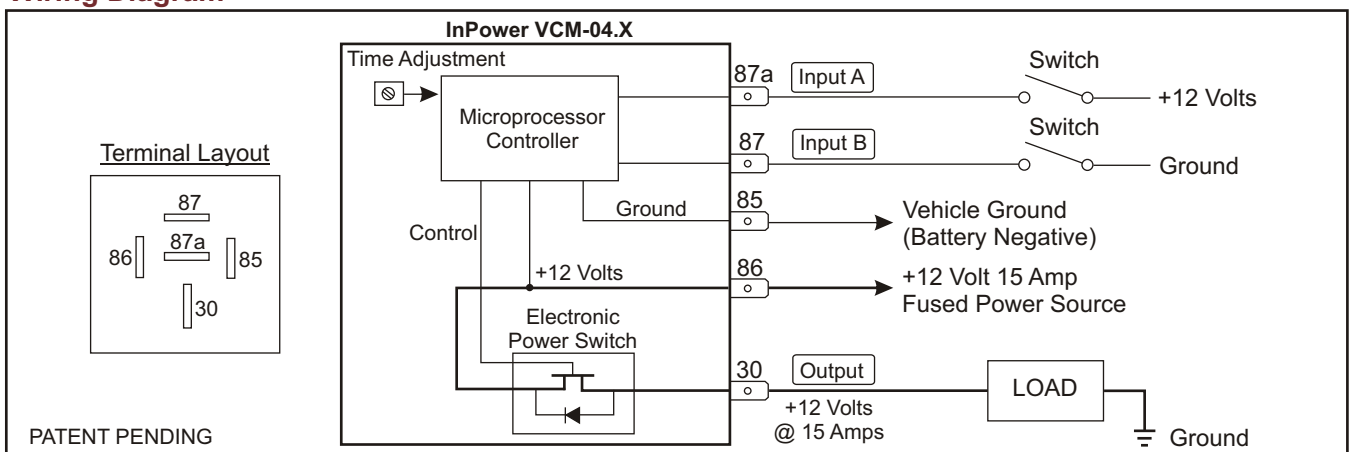

VCM-04.X

Time Delay Solid State Relay, Off-Delay

Specifications

Power Input (86):	+8 to 16 Vdc @ 15 amps
Ground (85):	Connection to vehicle ground (Battery Negative)
Input A (87a):	External contact closure to +12 volts
Input B (87):	External contact closure to ground
Module Output (30):	+12 volts @ 15 amps

Mechanical

Weight:	0.10 lbs.
Operating Temperature:	-40° C to +85° C
Dimensions:	1.75" H x 2.30" W x 1.25" D

Timing Diagram

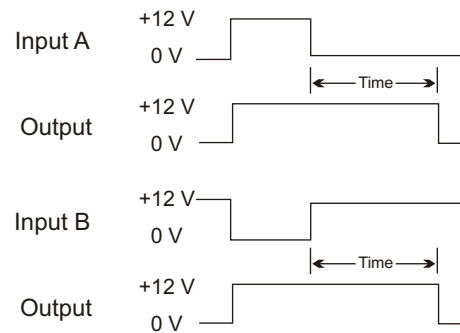

Installation

1. We recommend that the module be installed by a person trained and skilled in vehicle electrical systems. The installation should comply with SAE (Society of Automotive Engineers) and the vehicle manufacturer's electrical wiring procedures (e.g., Ford, General Motors, etc.).
2. The module should be installed on the inside of the vehicle in a dry and protected environment.
3. For optimum power output performance the product should be mounted to a metal surface.
4. Do not connect loads to the output that will exceed the output current rating of the module.
5. The 12 volt power input (86) must be from a properly fused +12 volt power source.
6. Wiring must be of the proper gage and type to handle the intended load currents.
7. We recommend the use of insulated 1/4 inch female blade terminals that connect to the terminals on the module. Be sure to properly crimp these terminals. **Do not solder wires directly to the module terminals.**
8. If you are experiencing problems with the installation or need troubleshooting assistance, contact InPower Customer Service at 740-548-0965.

Outline Drawing

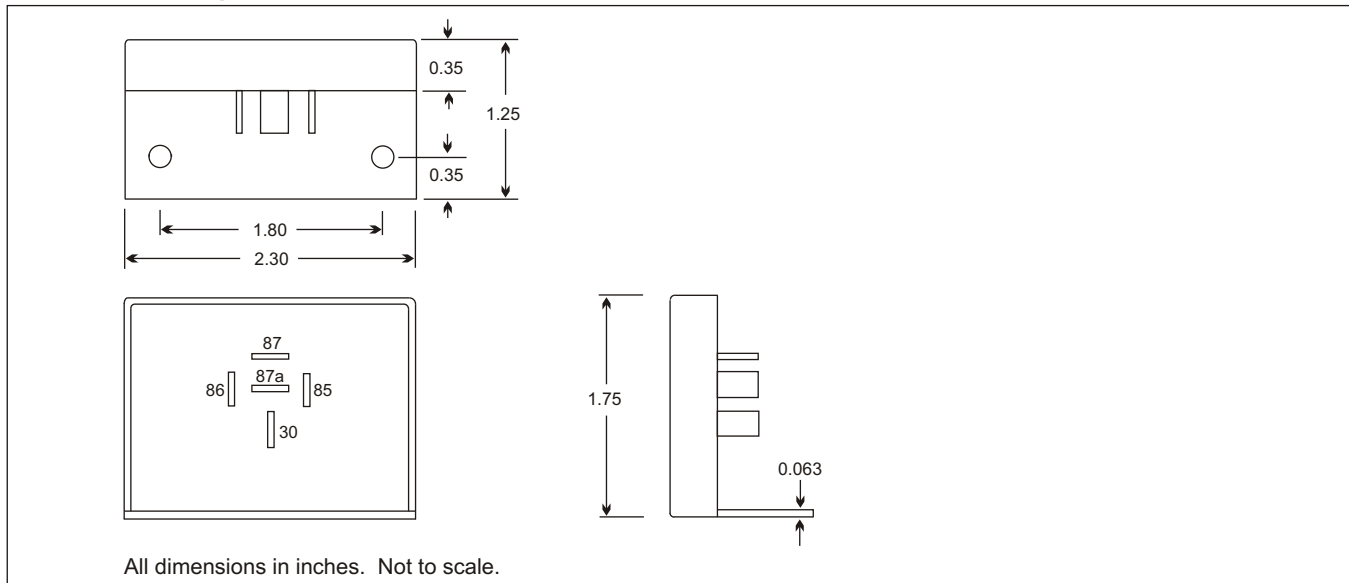

InPOWER LLC

3555 Africa Road
Galena, Ohio 43021
Tel 740-548-0965
Fax 740-548-2302

www.InPowerDirect.com

Offered by: