



### VCM-08 Dual 15 Amp Alternating Lamp Flasher

InPower's VCM Series *Vehicle Control Modules* are a set of "tools" for the designers of vehicle electrical control systems. These solid state modules are designed to withstand the environments typically found on trucks, emergency vehicles, buses, coaches and speciality vehicles, and are available in a variety of standard and custom configurations and functions.

#### Technical Description

The InPower VCM-08 warning lamp flasher represents a breakthrough in solid state flasher technology. The use of advanced SMT and packaging technology results in a very compact, high performance flasher with exceptional reliability and low cost.

The VCS-08 flasher is a completely solid state dual output alternating warning lamp flasher. Its outputs are rated at +12 volts @ 15 amps each, and are designed to operate high in-rush current halogen and incandescent lamps, as well as LED lights.

When a ground is applied to the input, the outputs will alternately flash at a rate of 75 cycles per minute at a 50% duty cycle. The solid state outputs are a unique design that will automatically shut off if an over current or short circuit fault occurs. If a fault shut down occurs on one output the other output will remain operational.

#### Key Features

- 100% Solid State Construction
- Operates Halogen and LED Lamps
- Standard Automotive Relay Pin Format
- Dual 12 Volt 15 Amp Solid State Outputs
- Compact Size with Panel-Mount Bracket
- High Technology Power Switching Circuit
- Durable Metal Case

#### Ordering Guide

| Model  | Description   |
|--------|---|
| VCM-08 | Solid state alternating lamp flasher with single input and two +12 volt @ 15 amp outputs. |

#### Wiring Diagram

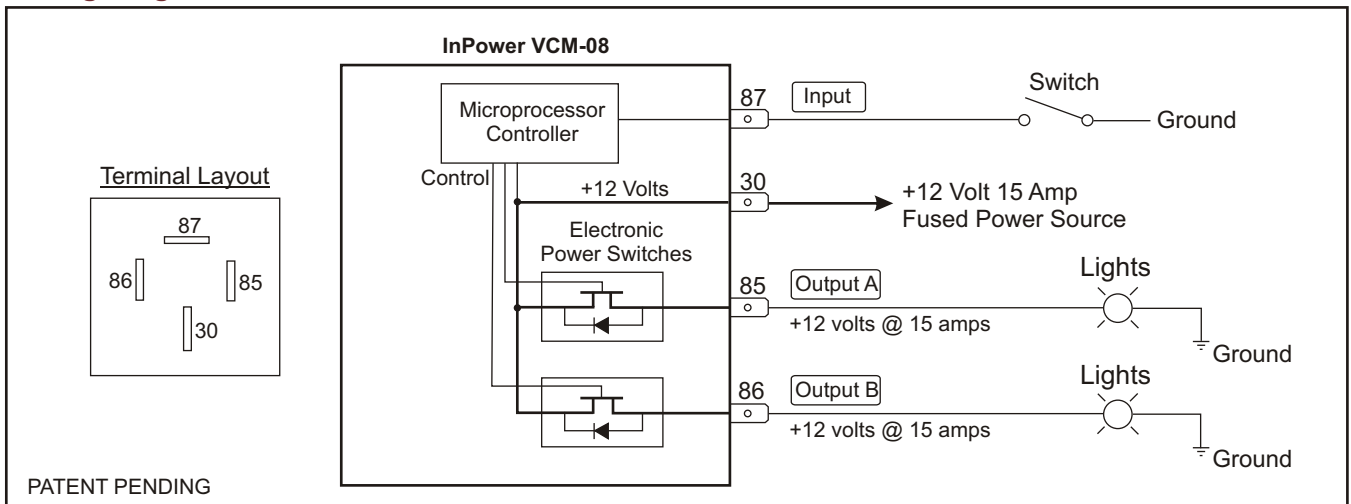

# VCM-08

## Solid State Dual 15 Amp Alternating Flasher

### Specifications

|                     |                                    |
|---------------------|------------------------------------|
| Power Input (30):   | +8 to 16 Vdc @ 15 amps             |
| Control Input (87): | External contact closure to ground |
| Output A (85):      | +12 volts @ 15 amps                |
| Output B (86):      | +12 volts @ 15 amps                |
| Flash Rate:         | 75 per minute                      |

### Mechanical

|                        |                  |
|------------------------|------------------|
| Weight:                | 0.10 lbs.        |
| Operating Temperature: | -40° C to +85° C |

### Timing Diagram

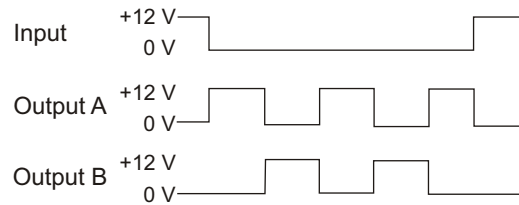

### Installation

1. We recommend that the module be installed by a person trained and skilled in vehicle electrical systems. The installation should comply with SAE (Society of Automotive Engineers) and the vehicle manufacturer's electrical wiring procedures (e.g., Ford, General Motors, etc.).
2. The module should be installed on the inside of the vehicle in a dry and protected environment.
3. For optimum power output performance the product should be mounted to a metal surface.
4. Do not connect loads to the output that will exceed the output current rating of the module.
5. The 12 volt power input (30) must be from a properly fused +12 volt power source.
6. Wiring must be of the proper gage and type to handle the intended load currents.
7. We recommend the use of insulated 1/4 inch female blade terminals that connect to the terminals on the module. Be sure to properly crimp these terminals. **Do not solder wires directly to the module terminals.**
8. If you are experiencing problems with the installation or need troubleshooting assistance, contact InPower Customer Service at 740-548-0965.

### Outline Drawing

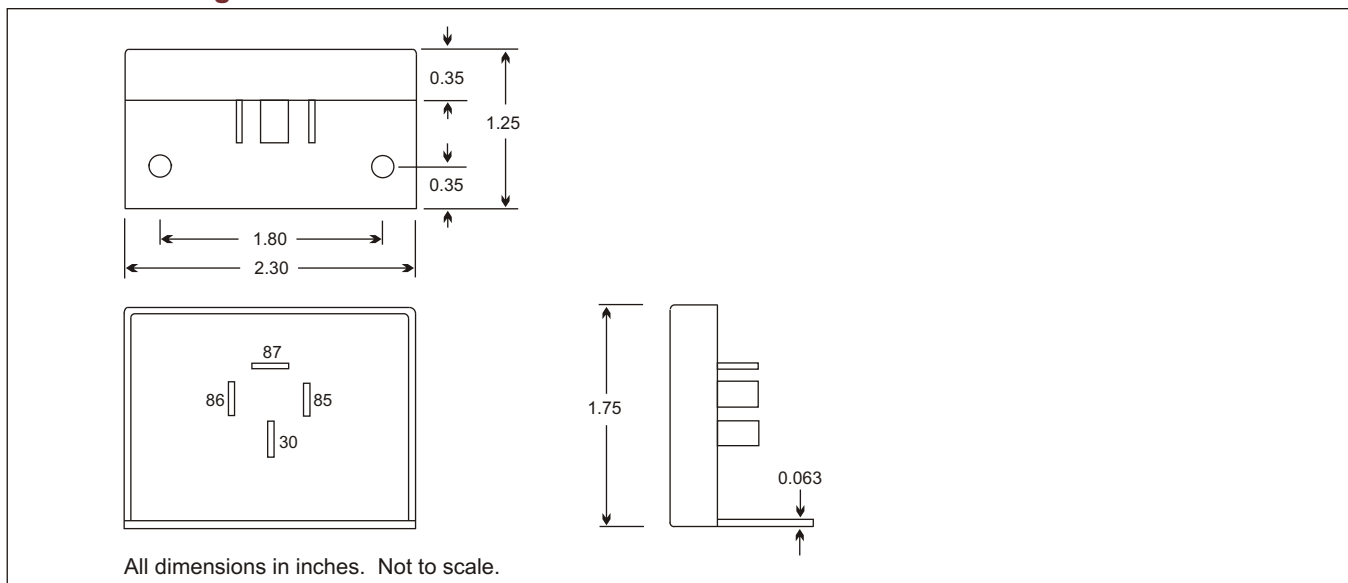

**InPOWER LLC**  
3555 Africa Road  
Galena, Ohio 43021  
Tel 740-548-0965  
Fax 740-548-2302  
www.InPowerDirect.com

**Offered by:**