

Digital Voltmeter/Ammeter

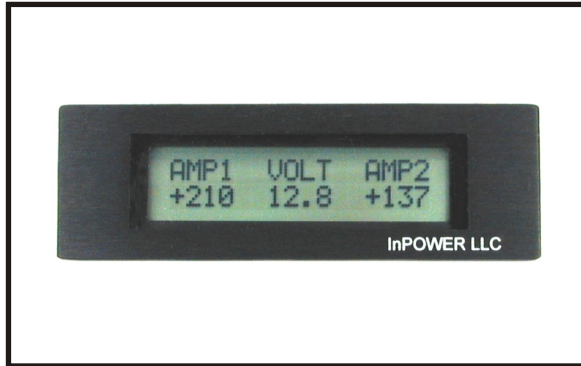

Digital battery monitor and alarm displays battery voltage and up to two ammeters

The InPower DSP-DCS1 is a multifunction instrument that includes a DC voltmeter and two ammeters. Its backlit liquid crystal display (LCD) is easy to read in low ambient light conditions as well as in direct sunlight. A built-in low battery voltage alarm is provided that complies with Federal Specification KKK-A-1822F, Paragraph 3.7.6.2 (*Voltmeter and Voltage Monitor*). This alarm function provides a flashing battery voltage display and sets the Alarm output (+12 volts @ 0.5 amps) when the battery voltage drops below 11.8 volts for 120 seconds. Also provided is a Silence Alarm control input. If the Alarm output is set and a ground is applied to the Silence Alarm input the Alarm output will be turned off, but the voltage display will continue to flash until the battery voltage rises above 12.25 volts for two minutes.

The dual ammeter function utilizes InPower Model DCS-35-300-1 Hall-effect current sensors to measure DC current in the range of -300 to +300 amps. As the system is pre-calibrated there is no need for adjustments at installation. The system provides an automatic configuration that detects if one, two, or no current sensors are connected, and automatically formats the digital display accordingly. For example, if no current sensors are detected the display will only show the battery voltage information.

The DSP-DCS1 battery monitor mounts easily on a flat panel with cutout. No fasteners are visible from the front. It contains 0.25 inch Faston male blade terminals on the rear of the unit for the interface connections.

Key Features

- **Battery DC Voltage Display**
- **Dual DC Ammeter Display**
- **Backlit LCD Digital Display**
- **Low Battery Voltage Alarm (KKK-A-1822F)**
- **Auto-Configures Number of Ammeters**
- **Uses Standard InPower DC Current Sensors**
- **No Calibration Required**

Wiring Diagram

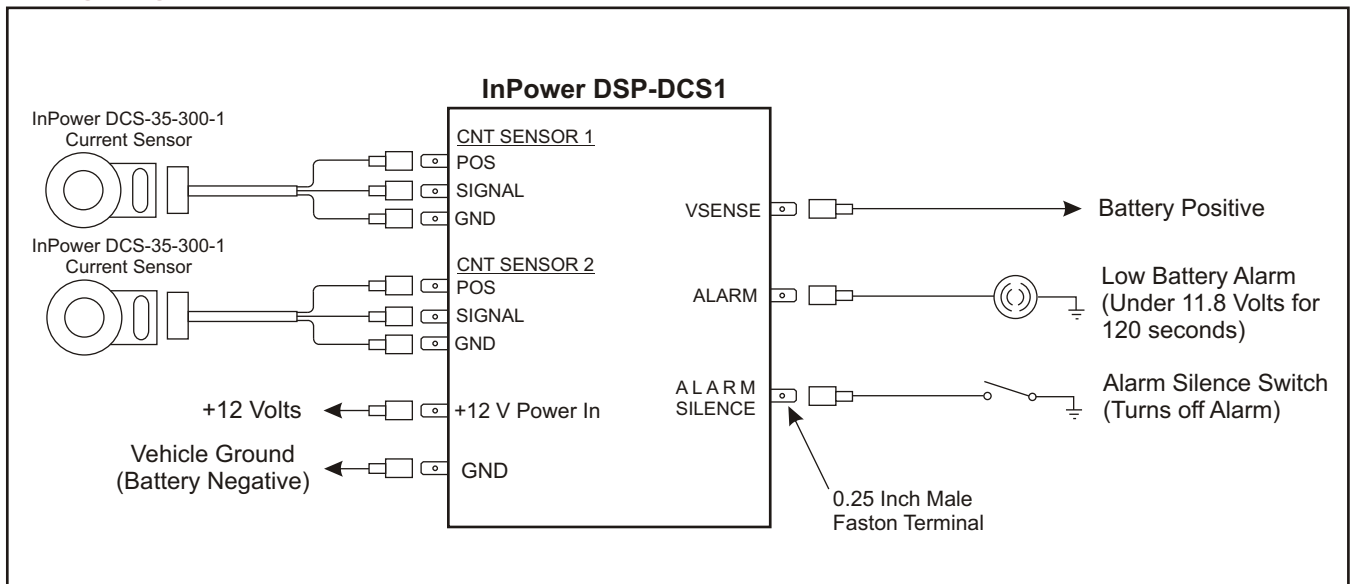

DSP-DCS1

Digital Voltmeter/Ammeter

Specifications

Operating Voltage Range:	+8 to +16 Vdc
Operating Current Range:	0.065 amps for the display, plus the current used by the Alarm control output (0-0.5 amps)
Voltmeter Measurement Range:	0 Vdc to 20 Vdc
Ammeter Range:	-300 to +300 amps
Ammeter Sensor:	InPower Model DC35-300-1 (One or two Required)
Terminals:	Male 0.25 inch Faston (blade)
Display Type:	Backlit LCD
Display Character Height:	0.20 Inch (20 mm)
Alarm System:	
Compliance:	Federal specification KKK-A-1822F, Paragraph 3.7.6.2
Low Voltage Indication:	The voltage display will flash when the Battery Sense is <11.8 Vdc for 120 seconds
Alarm Control Output:	+12 volts @ 0.5 amps when Battery Sense is <11.8 Vdc for >120 seconds
Silence Alarm Control Input:	Apply ground to turn off Alarm output. Resets when Battery Sense returns to above 12.25 Vdc for two minutes
Operating Temperature:	-20° C to +80° C

Outline Drawing

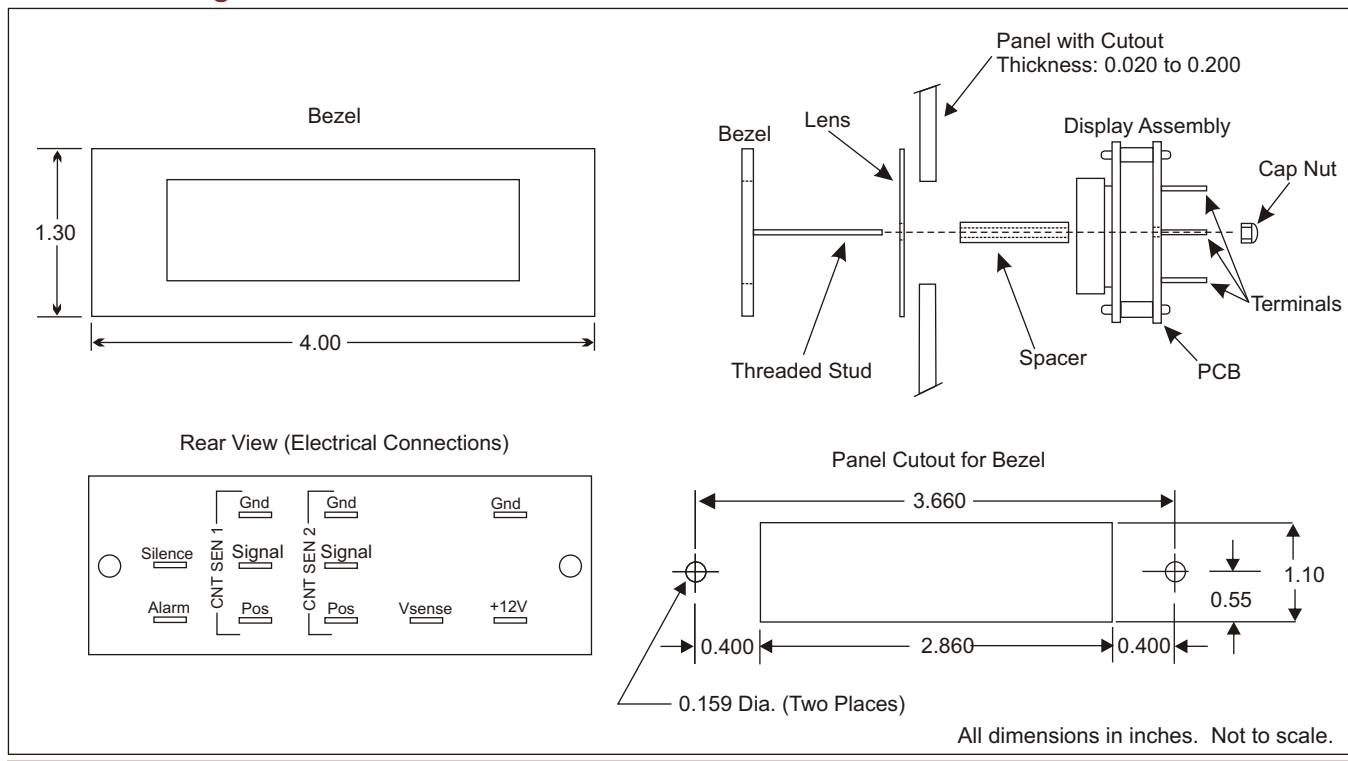

InPOWER LLC
3555 Africa Road
Galena, Ohio 43021
Tel 740-548-0965
Fax 740-548-2302
www.InPowerDirect.com

Offered by: