

## LVD10 Series Low Voltage Disconnect

LVD10-100-115 (100 Amps/11.5 Volts)  
LVD10-100-080 (100 Amps/8.0 Volts)  
LVD10-200-115 (200 Amps/11.5 Volts)  
LVD10-200-080 (200 Amps/8.0 Volts)



*Solid state DC disconnect switch with low battery voltage shut off and over current protection.*

InPower's LVD10 Series low voltage disconnect switches are a family of solid state DC contactors that shut off when the battery voltage drops below its fixed voltage setpoint. Models available include 100 and 200 Amp, and 8.0 and 11.5 volts disconnect voltages. The LVD disconnect switches operate as a solid state DC contactor with a control input terminal. When positive voltage is applied to this input the contactor actuates, applying battery voltage to its load output. When the contactor is actuated, its controller continuously monitor the battery voltage at its battery terminal. When the battery voltage drops below its fixed voltage preset for the specified time period it will deactivate the contactor, removing power from its output load terminal. This will disconnect power draw on the battery so that sufficient energy remains in the battery for starting. When the battery has been recharged and the battery voltage exceeds the shut off preset the LVD disconnect can be re-actuated. This is done by removing the control input voltage and re-applying it.

These advanced technology products also feature automatic shutdown for over current, high temperature, and loss of ground conditions. In the event of a shutdown the disconnect switch will remain latched in the off state. When the fault is cleared the control input voltage must removed and re-applied to activate the unit.

The low voltage disconnect is packaged in a totally sealed case, and its four mounting hole pads provide the required connection to ground. The control input utilizes a ¼ inch Faston blade terminal. Connections for the high current battery and load cables utilize 3/8-16 threaded stainless steel studs with brass contact pads for low contact resistance. They also contain detent grooves that allow rubber terminal boots to be used for additional protection from the environment, as well as from accidental shorting.

### Key Features

- Prevents excessive battery discharge by automatically disconnecting loads.
- 100% solid state design - No moving parts to cause arcing and electrical noise.
- Automatic shutdown protection for short-circuit, over-current and high temperature.
- Sealed construction is resistant to mechanical shock and vibration.
- Low on-resistance power switch has low voltage drop and temperature rise.
- Compact Size and Low Profile.
- Rubber Terminal Boot Option

### System Diagram

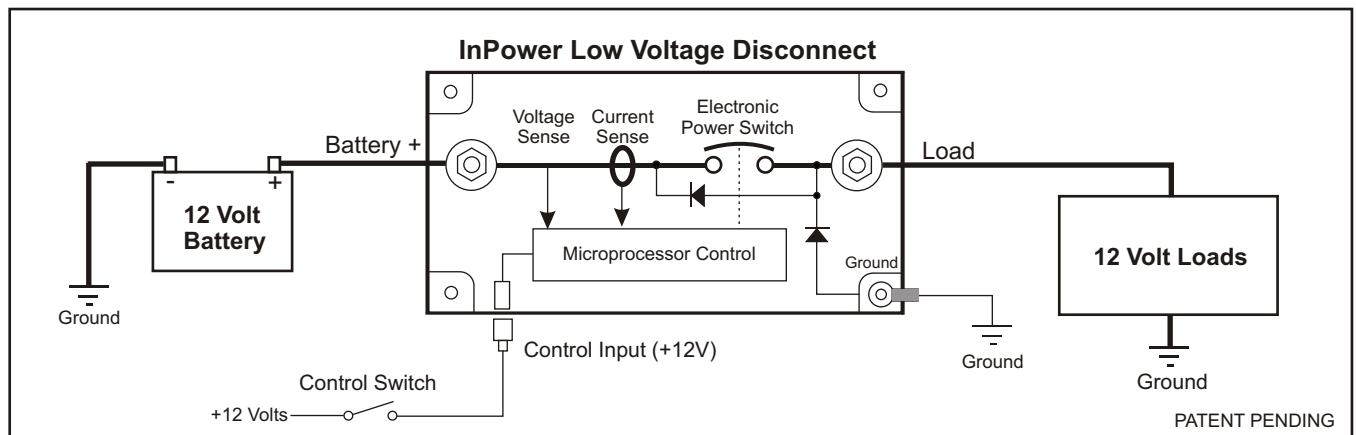

# LVD10 Series Low Voltage Disconnects

## Specifications

	LVD10-100-115	LVD10-100-080	LVD10-200-11.5	LVD10-200-080
Maximum Current Rating:	100 Amps	100 Amps	200 Amps	200 Amps
Shut Off Voltage:	11.5 Vdc	8.0 Vdc	11.5 Vdc	8.0 Vdc
Shut Off Time Period:	2.0 Minutes	2.0 Minutes	1.0 Seconds	1.0 Seconds

Note - The contactor will shut off when the battery voltage remains below the Shut Off Voltage for the specified Shut Off Time Period.

Operating Voltage Range:	+9.5 to +18.5 volts (14.2 volt nominal)
Case Maximum Temperature:	+185°F (+85° C)
Control Connector Type:	0.250 inch male Faston blade terminal
Control Input Voltage:	>+9.5 Vdc to activate; <+8.0 Vdc to deactivate
Control Input Current:	Zero current draw when input is deactivated. When input is activated, current draw is 10 milliamps @13.5 Vdc input voltage.
Fault Shutdown Reset:	For over current, short circuit, over temperature or loss of ground shutdowns the fault must be cleared, then the control input voltage must be removed and re-applied to actuate the contactor.
Low Voltage Shut Off:	When the battery terminal voltage drops below the fixed voltage set point for the specified time period the contactor will open and remain latched in the off state. To reset the unit the battery voltage must rise above the Shut Off Voltage and the control input voltage must be removed and re-applied.
Weight:	0.30 lbs (0.136 kg)
Dimensions:	2.7 x 4.2 x 0.925 inches (68.6 x 106.7 x 23.5 mm)
Power Terminals:	Two (2) 3/8 - 16 threaded stainless steel studs, with nuts and lock washers. Rubber terminal boot covers are optional.

## Mechanical Drawing

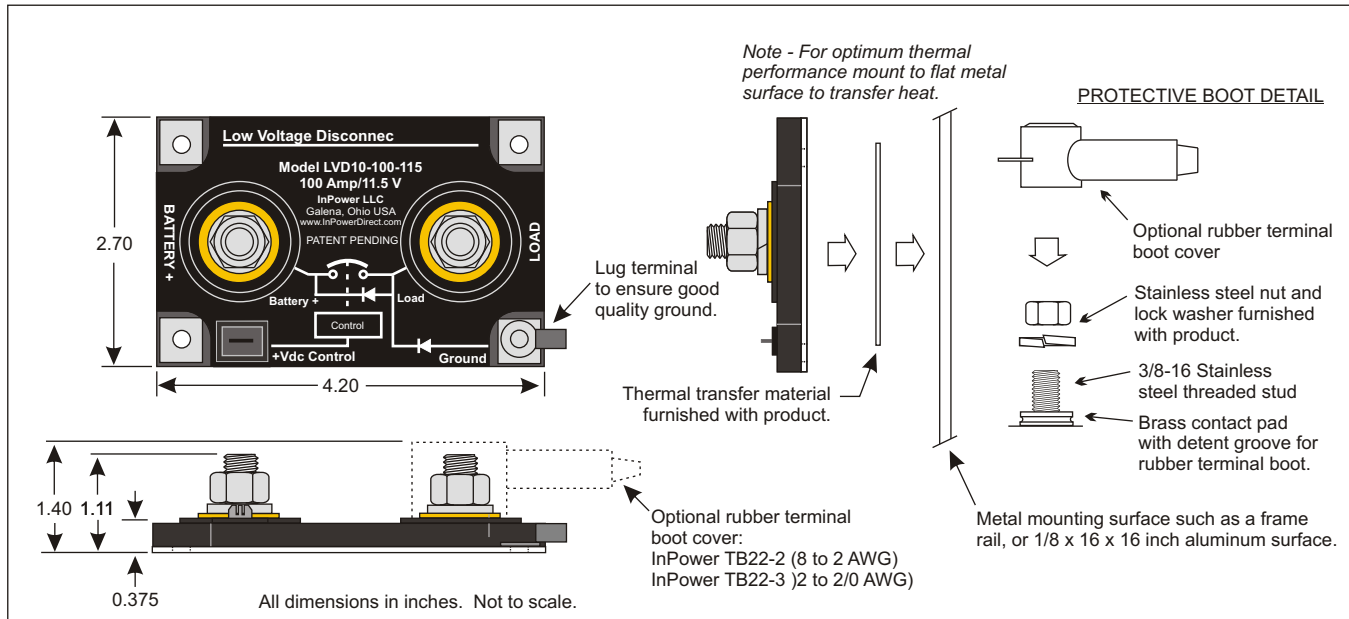

### InPOWER LLC

3555 Africa Road  
 Galena, Ohio 43021  
 Tel 740-548-0965  
 Fax 740-548-2302  
 www.InPowerLLC.com

**Offered by:**